

DRAFT Posted

**FLORIDA DEPARTMENT OF ENVIRONMENTAL PROTECTION**

Division of Environmental Assessment and Restoration, Bureau of Watershed  
Restoration

CENTRAL DISTRICT • KISSIMMEE RIVER BASIN • UPPER KISSIMMEE PLANNING  
UNIT

**TMDL Report**

**Nutrient TMDL  
For Lake Kissimmee  
WBID 3183B**

**Douglas Gilbert**



**July 29, 2011**

## Acknowledgments

---

This study could not have been accomplished without the funding support of the Florida Legislature. Contractual services were provided by Camp Dresser and McKee under contract WM912. Sincere thanks to CDM for the support from Lena Rivera (Project Manager), Silong Lu (hydrology), and Richard Wagner (water quality). Additionally, significant contributions were made by the staff in the Florida Department of Environmental Protection's (the Department) Watershed Assessment Section, particularly Barbara Donner for GIS support. The Department also recognizes the substantial support and assistance from the Department's Central District Office, South Florida Water Management district (SFWMD), Polk County, Osceola County and their contributions towards understanding the issues, history, and processes at work in the Lake Kissimmee watershed.

Editorial assistance provided by Jan Mandrup-Poulsen and Linda Lord.

For additional information on the watershed management approach and impaired waters in The Upper Kissimmee River Planning Unit, contact:

Beth Alvi  
Florida Department of Environmental Protection  
Bureau of Watershed Restoration  
Watershed Planning and Coordination Section  
2600 Blair Stone Road, Mail Station 3565  
Tallahassee, FL 32399-2400  
Elizabeth.alvi@dep.state.fl.us  
Phone: (850) 245-8559;  
Fax: (850) 245-8434

Access to all data used in the development of this report can be obtained by contacting:

Douglas Gilbert, Environmental Manager  
Florida Department of Environmental Protection  
Bureau of Watershed Restoration  
Watershed Evaluation and TMDL Section  
2600 Blair Stone Road, Mail Station 3555  
Tallahassee, FL 32399-2400  
douglas.gilbert@dep.state.fl.us  
Phone: (850) 245-8450  
Fax: (850) 245-8536

# Contents

<b>CHAPTER 1: INTRODUCTION</b> .....	<b>1</b>
1.1 Purpose of Report.....	1
1.2 Identification of Waterbody.....	1
1.3 Background Information .....	4
<b>CHAPTER 2: STATEMENT OF WATER QUALITY PROBLEM</b> .....	<b>6</b>
2.1 Legislative and Rulemaking History.....	6
2.2 Information on Verified Impairment.....	6
<b>CHAPTER 3. DESCRIPTION OF APPLICABLE WATER QUALITY STANDARDS AND TARGETS</b> .....	<b>19</b>
3.1 Classification of the Waterbody and Criteria Applicable to the TMDL.....	19
3.2 Interpretation of the Narrative Nutrient Criterion for Lakes.....	19
3.3 Narrative Nutrient Criteria Definitions .....	21
<b>CHAPTER 4: ASSESSMENT OF SOURCES</b> .....	<b>22</b>
4.1 Overview of Modeling Process .....	22
4.2 Potential Sources of Nutrients in the Lake Kissimmee Watershed.....	22
4.3 Estimating Point and Nonpoint Source Loadings .....	30
<b>CHAPTER 5: DETERMINATION OF ASSIMILATIVE CAPACITY</b> .....	<b>36</b>
5.1 Determination of Loading Capacity .....	36
5.2 Model Calibration/Validation.....	45
5.3 Background Conditions .....	91
5.4 Selection of TMDL Target.....	91
5.5 Critical Conditions .....	94
<b>CHAPTER 6: DETERMINATION OF THE TMDL</b> .....	<b>95</b>
6.1 Expression and Allocation of the TMDL.....	95
6.2 Load Allocation (LA).....	96
6.3 Wasteload Allocation (WLA) .....	96
6.4 Margin of Safety (MOS).....	97
<b>CHAPTER 7: NEXT STEPS: IMPLEMENTATION PLAN DEVELOPMENT AND BEYOND</b> .....	<b>98</b>
7.1 Basin Management Action Plan.....	98
7.2 Other TMDL Implementation Tools.....	99
<b>REFERENCES</b> .....	<b>100</b>

***APPENDICES* ..... 103**

**Appendix A: Background Information on Federal and State Stormwater Programs.....103**

**Appendix B: Electronic Copies of Measured Data and CDM, 2008 Report for Lake Kissimmee TMDL.....104**

**Appendix C: HSPF Water Quality Calibration Values for Lake Kissimmee .....105**

**Appendix D: Raw Data for Lake Kissimmee .....106**

## Tables

Table 2.1	Water Quality Summary Statistics for TN, NH <sub>3</sub> , NO <sub>2</sub> , TP, PO <sub>4</sub> , Chlorophyll a, Color, Alkalinity, pH, and Secchi	18
Table 4.1	NPDES Facilities	23
Table 4.2	Extended Watershed and Lake sub-basin Existing Land Use Description	25
Table 4.3	Septic Tank Coverage for Urban Land Uses	29
Table 4.4	Percentage of Impervious Area	32
Table 5.1	Hourly Rainfall Stations	37
Table 5.2	SFWMD Pan Evaporation and Potential Evapotranspiration Monitoring Stations	43
Table 5.3	SFWMD Air Temperature, Solar Radiation, and Wind Speed Monitoring Stations	43
Table 5.4	Calibration Monthly Average Stage JMP Means Comparison	48
Table 5.5	Validation Monthly Average Stage JMP Means Comparison	49
Table 5.6	HSPF Simulated Annual Water Budget for Lake Kissimmee	50
Table 5.7	Land-Based Water Quality Input Parameter Values	51
Table 5.8	Average Annual Land-Based Loading by Land Use Type and Soil Group	52
Table 5.9	Calibration Daily Temperature JMP Means Comparison	54
Table 5.10	Validation Daily Temperature JMP Means Comparison	55
Table 5.11	Total Nitrogen Annual Average Calibration JMP Means Comparison	60
Table 5.12	Total Nitrogen Annual Average Validation JMP Means Comparison	61
Table 5.13	Total Nitrogen Annual Average JMP Means Comparison 1997 - 2006	62
Table 5.14	Total Ammonia Annual Average Calibration JMP Means Comparison	65
Table 5.15	Total Ammonia Annual Average Validation JMP Means Comparison	66
Table 5.16	Total Ammonia Annual Average JMP Means Comparison 1997 - 2006	67
Table 5.17	Total Phosphorus Annual Average Calibration JMP Means Comparison	69
Table 5.18	Total Phosphorus Annual Average Validation JMP Means Comparison	70
Table 5.19	Total Phosphorus Annual Average JMP Means Comparison 1997 – 2006	71
Table 5.20	Ortho-phosphate Annual Average Calibration JMP Means Comparison	74
Table 5.21	Ortho-phosphate Annual Average Validation JMP Means Comparison	75
Table 5.22	Ortho-phosphate Annual Average JMP Means Comparison 1997 - 2006	76
Table 5.23	Corrected Chlorophyll <i>a</i> Annual Average Calibration JMP Means Comparison	79
Table 5.24	Corrected Chlorophyll <i>a</i> Annual Average Validation JMP Means Comparison	80
Table 5.25	Corrected Chlorophyll <i>a</i> Annual Average JMP Means Comparison 1997 - 2006	81
Table 5.26	TSI Annual Average Calibration JMP Means Comparison	84
Table 5.27	TSI Annual Average Validation JMP Means Comparison	85
Table 5.28	TSI Annual Average JMP Means Comparison 1997 - 2006	86
Table 5.29	TN-TSI Annual Average Validation JMP Means Comparison	87
Table 5.30	TP-TSI Annual Average Validation JMP Means Comparison	88
Table 5.31	HSPF Simulated Total Phosphorus Budget for Lake Kissimmee from 1997 to 2006 in Pounds/Year	89
Table 5.32	HSPF Simulated Total Nitrogen Budget for Lake Kissimmee from 1997 to 2006 in Pounds/Year	90
Table 5.33	Background Land Use Model Results	91
Table 5.34	Existing and TMDL Watershed TN and TP Loads and Percent Reductions Average of 1997 – 2006 Model Years	94
Table 6.1	Lake Kissimmee TMDL Load Allocations	96

**Figures**

Figure 1.1 The Upper Kissimmee Planning Unit and Lake Kissimmee Watershed \_\_\_\_\_ 2

Figure 1.2 Lake Kissimmee WBID 3183B and Monitoring Stations \_\_\_\_\_ 3

Figure 2.1 Daily Average Color (PCU) \_\_\_\_\_ 8

Figure 2.2 Annual Average Color (PCU) 1970 - 2010 \_\_\_\_\_ 8

Figure 2.3 Daily Average Alkalinity (mg/L) \_\_\_\_\_ 9

Figure 2.4 Daily Average pH (S.U.) \_\_\_\_\_ 9

Figure 2.5 Daily Average Secchi (meters) \_\_\_\_\_ 10

Figure 2.6 TSI Annual Average (1975 – 2010) \_\_\_\_\_ 12

Figure 2.7 Total Nitrogen Daily Average Results \_\_\_\_\_ 12

Figure 2.8 Total Nitrogen Annual Average Results \_\_\_\_\_ 13

Figure 2.9 Total Nitrogen Monthly Average Results \_\_\_\_\_ 13

Figure 2.10 Total Ammonia Nitrogen Daily Average Results \_\_\_\_\_ 14

Figure 2.11 Total Phosphorus Daily Average Results \_\_\_\_\_ 14

Figure 2.12 Total Phosphorus Annual Average Results \_\_\_\_\_ 15

Figure 2.13 Total Phosphorus Monthly Average Results \_\_\_\_\_ 15

Figure 2.14 Ortho-Phosphate - Phosphorus Daily Average Results \_\_\_\_\_ 16

Figure 2.15 Corrected Chlorophyll a Daily Average Results \_\_\_\_\_ 16

Figure 2.16 Corrected Chlorophyll a Annual Average Results \_\_\_\_\_ 17

Figure 2.17 Corrected Chlorophyll a Monthly Average Results \_\_\_\_\_ 17

Figure 4.1 Lake Kissimmee Watershed Existing Land Use Coverage \_\_\_\_\_ 26

Figure 4.2 Lake Kissimmee (Reach 480) HSPF Modeled Watershed Flow Routing and  
Reach Numbers \_\_\_\_\_ 31

Figure 5.1 Hourly Rainfall Stations Lake Kissimmee Watershed \_\_\_\_\_ 39

Figure 5.2 Daily Rainfall used in model (1996-2006) \_\_\_\_\_ 40

Figure 5.3 Monthly Average Rainfall from Model dataset \_\_\_\_\_ 40

Figure 5.4 Annual Average Rainfall from Model dataset (1996-2006) \_\_\_\_\_ 41

Figure 5.5 SFWMD Pan Evaporation and Potential Evapotranspiration Monitoring  
Stations in Lake Kissimmee Watershed \_\_\_\_\_ 42

Figure 5.6 SFWMD Air Temperature, Solar Radiation, and Wind Speed Monitoring  
Stations \_\_\_\_\_ 44

Figure 5.7 Calibration and Validation Measured and Simulated Lake Stage \_\_\_\_\_ 47

Figure 5.8 Calibration Results for Monthly Average Measured and Simulated Lake  
Stage \_\_\_\_\_ 48

Figure 5.9 Validation Results for Monthly Average Measured and Simulated Lake Stage  
\_\_\_\_\_ 49

Figure 5.10 Measured and Simulated Lake Temperature \_\_\_\_\_ 53

Figure 5.11 Calibration Results for Daily Measured and Simulated Lake Temperature \_\_\_\_\_ 54

Figure 5.12 Validation Results for Daily Measured and Simulated Lake Temperature \_\_\_\_\_ 55

Figure 5.13 Total Nitrogen Daily Measured Data and Simulated Results (1996 - 2006) \_\_\_\_\_ 58

Figure 5.14 Total Nitrogen Annual Average Measured Data (1996 – 2009) and  
Simulated Results (1996 - 2006) \_\_\_\_\_ 59

Figure 5.15 Total Nitrogen (mg/L) Annual Average Calibration \_\_\_\_\_ 60

Figure 5.16 Total Nitrogen (mg/L) Annual Average Validation \_\_\_\_\_ 61

Figure 5.17 Total Nitrogen (mg/L) Annual Average 1997 - 2006 \_\_\_\_\_ 62

Figure 5.18 Total Ammonia Daily Measured Data and Simulated Results (1996 - 2006)  
\_\_\_\_\_ 63

Figure 5.19 Total Nitrogen Ammonia Annual Average Measured Data (1996 – 2009) and Simulated Results (1996 - 2006)	64
Figure 5.20 Total Ammonia (mg/L) Annual Average Calibration	64
Figure 5.21 Total Ammonia (mg/L) Annual Average Validation	65
Figure 5.22 Total Ammonia (mg/L) Annual Average 1997 - 2006	66
Figure 5.23 Total Phosphorus Daily Measured Data and Simulated Results (1996 - 2006)	67
Figure 5.24 Total Phosphorus Annual Average Measured Data (1996 – 2009) and Simulated Results (1996 - 2006)	68
Figure 5.25 Total Phosphorus (mg/L) Annual Average Calibration	69
Figure 5.26 Total Phosphorus (mg/L) Annual Average Validation	70
Figure 5.27 Total Phosphorus (mg/L) Annual Average 1997 - 2006	71
Figure 5.28a Ortho-phosphate Daily Measured Data and Simulated Results (1996 2006)	72
Figure 5.28b Ortho-phosphate Daily Measured Data and Simulated Results (1996 2006) without elevated values	72
Figure 5.29 Ortho-phosphate Annual Average Measured Data (1996 – 2009) and Simulated Results (1996 - 2006)	73
Figure 5.30 Ortho-phosphate (mg/L) Annual Average Calibration	74
Figure 5.31 Ortho-phosphate (mg/L) Annual Average Validation	75
Figure 5.32 Ortho-phosphate (mg/L) Annual Average 1997 - 2006	76
Figure 5.33 Corrected Chlorophyll <i>a</i> Daily Measured Data and Simulated Results (1996 - 2006)	77
Figure 5.34 Corrected Chlorophyll <i>a</i> Annual Average Measured Data (1996 – 2009) and Simulated Results (1996 - 2006)	78
Figure 5.35 Corrected Chlorophyll <i>a</i> (ug/L) Annual Average Calibration	79
Figure 5.36 Corrected Chlorophyll <i>a</i> (ug/L) Annual Average Validation	80
Figure 5.37 Corrected Chlorophyll <i>a</i> (ug/L) Annual Average 1997 - 2006	81
Figure 5.38 TSI Annual Average Measured Data (1996 – 2009) and Simulated Results (1996 - 2006)	83
Figure 5.39 TSI Annual Average Calibration	84
Figure 5.40 TSI Annual Average Validation	85
Figure 5.41 TSI Annual Average 1997 -2006	86
Figure 5.42 TN-TSI Annual Average Validation	87
Figure 5.43 TP-TSI Annual Average Validation	88
Figure 5.44 TSI for TMDL, Calibrated Model, and Background+5 TSI Units	93

## Web sites

### **FLORIDA DEPARTMENT OF ENVIRONMENTAL PROTECTION, BUREAU OF WATERSHED RESTORATION**

TMDL Program

<http://www.dep.state.fl.us/water/tmdl/index.htm>

Identification of Impaired Surface Waters Rule

<http://www.dep.state.fl.us/water/tmdl/docs/AmendedIWR.pdf>

STORET Program

<http://www.dep.state.fl.us/water/storet/index.htm>

2010 Integrated 305(b) Report

<http://www.dep.state.fl.us/water/305b/index.htm>

Criteria for Surface Water Quality Classifications

<http://www/dep.state.fl.us/legal/legaldocuments/rules/ruleslistnum.htm>

Basin Status Report for the Lake Kissimmee Basin

<http://www.dep.state.fl.us/water/basin411/kissimmee/index.htm>

Assessment Report for the Lake Kissimmee Basin

<http://www.dep.state.fl.us/water/basin411/kissimmee/index.htm>

Allocation Technical Advisory Committee (ATAC) Report

<http://www.dep.state.fl.us/water/tmdl/docs/Allocation.pdf>

### **U.S. ENVIRONMENTAL PROTECTION AGENCY, NATIONAL STORET PROGRAM**

<http://www.epa.gov/storet/>

---

# Chapter 1: INTRODUCTION

---

## 1.1 Purpose of Report

This report presents the TMDL for nutrients for Lake Kissimmee, located in the Kissimmee River Basin. Lake Kissimmee was initially verified as impaired during Cycle 1 (verified period January 1, 1998 – June 30, 2005) due to excessive nutrients using the methodology in the Identification of Impaired Surface Waters Rule (IWR, Rule 62-303, Florida Administrative Code), and was included on the Cycle 1 Verified List of impaired waters for the Kissimmee River Basin that was adopted by Secretarial Order on May 12, 2006. Subsequently, during the Cycle 2 assessment (verified period January 1, 2003 – June 30, 2010), the impairment for nutrients was documented as continuing, as the Trophic State Index (TSI) threshold of 40 (when color is 40 PCU or less) was exceeded in 2007 and the threshold of 60 (color greater than 40 PCU) in 2008. The TMDL establishes the allowable loadings to the lake that would restore the waterbody so that it meets its applicable water quality narrative criteria for nutrients.

## 1.2 Identification of Waterbody

Lake Kissimmee is located within Osceola County, Florida; however, the western edge of the lake is along the boundary between Polk County and Osceola County. The estimated average surface area of the lake is 37,000 acres, with a normal pool volume ranging between 216,000 acre/feet (ac/ft) and 368,000 ac/ft, with normal depths ranging between 8 to 12 feet. Lake Kissimmee receives the drainage from 831,208 acres through tributary inflow (Lake Hatchineha, Lake Rosalie, Tiger Lake, Lake Jackson, and Reach 410 of the HSPF model) and has a directly connected sub-basin surface water drainage area of approximately 70,321 acres for a total watershed acreage of 901,529 acres (**Figure 1.1**). The upstream drainage area land use is primarily wetland (29%), agriculture (24%), rangeland/upland forest (21%), pasture (9%), and residential/commercial (17%). The Lake Kissimmee sub-basin watershed's land use are rangeland/upland forest (32.1%), wetland (31.2%), agriculture (25.6%), pastureland (10.1%), and residential/commercial (1.1%). Water leaves Lake Kissimmee through the S65 structure, flowing into the Kissimmee River.

For assessment purposes, the Department has divided the Kissimmee River Basin into water assessment polygons with a unique **waterbody identification** (WBID) number for each watershed or stream reach. Lake Kissimmee has been given the WBID number of 3183B. The Lake Kissimmee WBID and its sampling/monitoring stations are illustrated in **Figure 1.2**.

Figure 1.1 The Upper Kissimmee Planning Unit and Lake Kissimmee Watershed

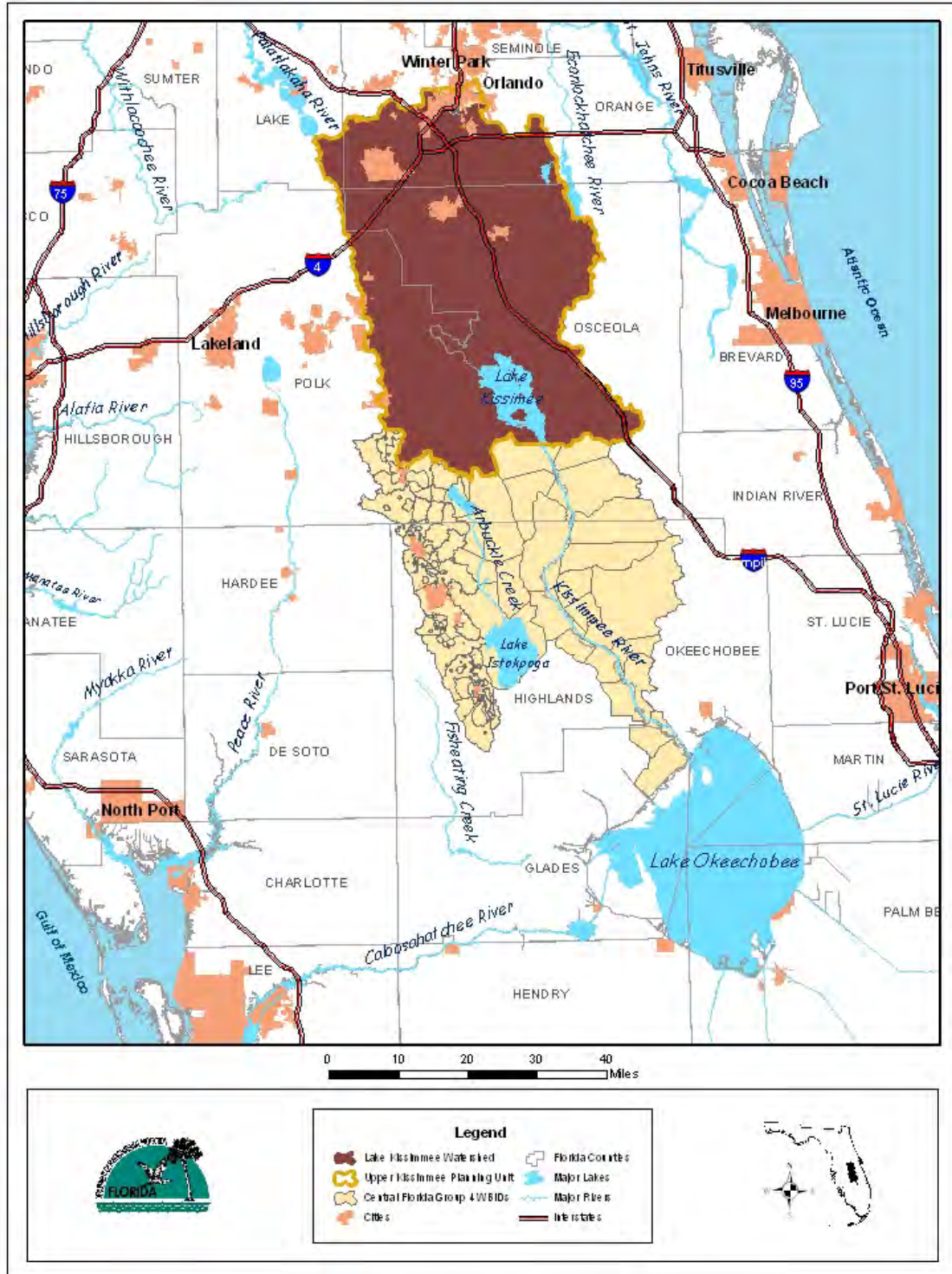
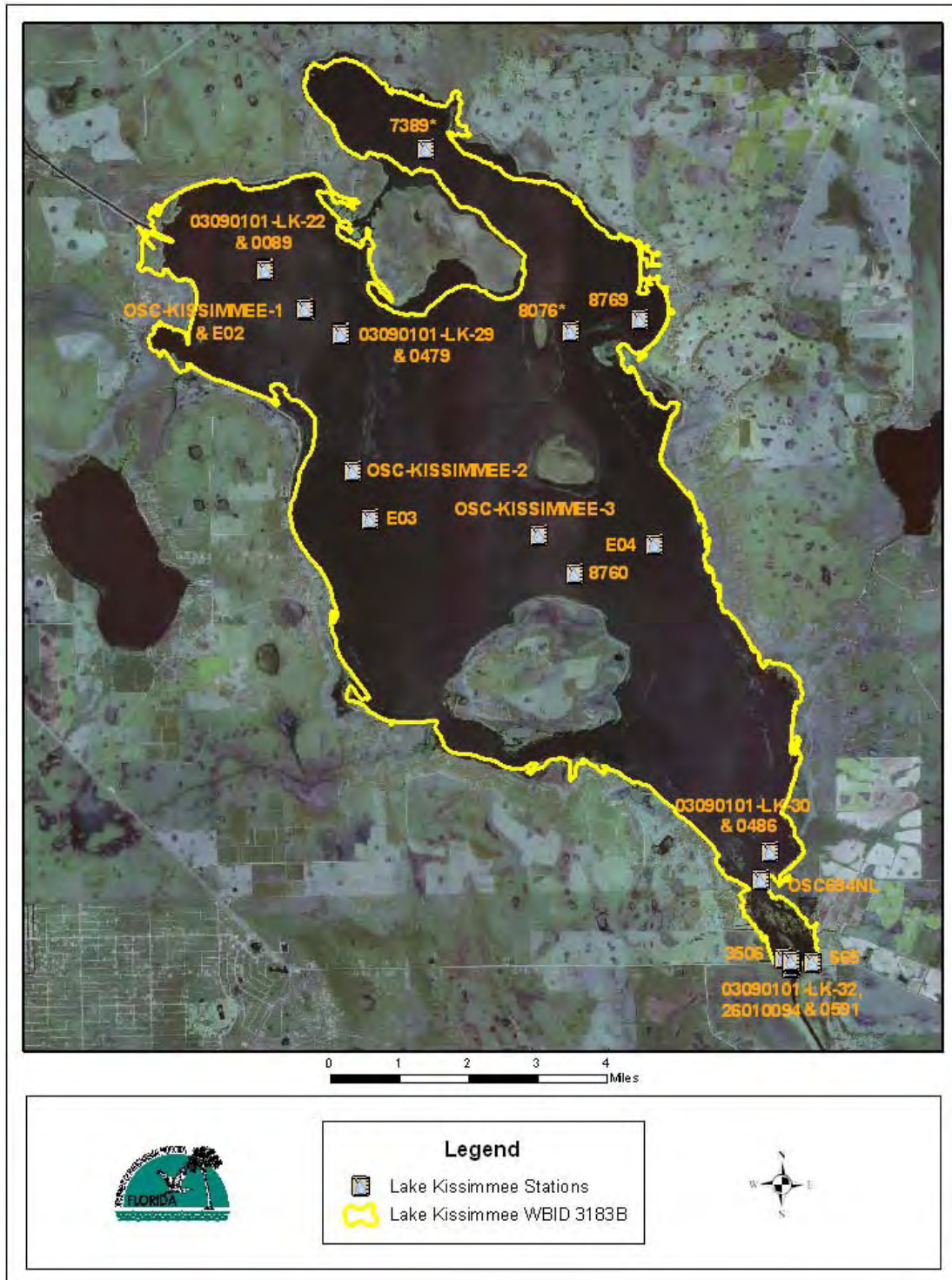


Figure 1.2 Lake Kissimmee WBID 3183B and Monitoring Stations



### 1.3 Background Information

As depicted in **Figure 1.1**, the Lake Kissimmee sub-basin has a total surface water drainage area of approximately 901,529 acres (831,208 acres upstream and 70,321 acres directly tributary to the lake). The Lake Kissimmee watershed includes upstream connections to Tiger Lake, Lake Rosalie, Lake Jackson, Lake Hatchineha, and model Reach 410 and a downstream connection to the Kissimmee River. Thus, the water quality and quantity in Lake Kissimmee directly influences water quality and quantity of the Kissimmee River. (**Figure 1.1**).

Several upstream waterbodies that contribute significant TN and TP loads to Lake Kissimmee [Lake Cypress (WBID 3180A), Lake Jackson (WBID 3183G), and Lake Marian (WBID 3184)] were verified as impaired by excessive nutrients using the methodology in the Identification of Impaired Surface Waters Rule (IWR, Rule 62-303, Florida Administrative Code), and were included on the Cycle 1, Group 4 Verified List of impaired waters for the Kissimmee River Basin that was adopted by Secretarial Order on May 12, 2006. The impaired condition for nutrients was documented as still present during the Cycle 2 verified period from January 1, 2003 – June 30, 2010. The draft TMDLs for these lakes are documented in the following reports; “Nutrient TMDL For Lake Cypress WBID 3180A,” “Nutrient and Dissolved Oxygen TMDL for Lake Jackson WBID 3183G,” and “Nutrient TMDL For Lake Marian WBID 3184,” and can be obtained from the Department’s TMDL web site:

<http://www.dep.state.fl.us/water/tmdl/index.htm>

The nutrient TMDL developed for Lake Cypress consisted of a 7 percent reduction for TN and a 53 percent reduction for TP from all watershed sources. The nutrient TMDL for Lake Marian consisted of a 50 percent reduction for TN and a 65 percent reduction for TP from all watershed sources. The nutrient TMDL for Lake Jackson consisted of a 12 percent reduction for TN and a 51 percent reduction for TP from all watershed sources. After the water quality model for Lake Kissimmee was calibrated to existing conditions, the development of the TMDL proceeded under the presumption that the TN and TP load reductions proposed for the upstream impaired Lakes Marian, Jackson, and Cypress have been achieved. The TMDL for Lake Kissimmee establishes the allowable loadings to the lake that would restore the waterbody so that it meets its applicable water quality narrative criteria for nutrients.

The TMDL Report for Lake Kissimmee is part of the implementation of the Florida Department of Environmental Protection’s (Department) watershed management approach for restoring and protecting water resources and addressing Total Maximum Daily Load (TMDL) Program requirements. The watershed approach, which is implemented using a cyclical management process that rotates through the state’s fifty-two river basins over a five-year cycle, provides a framework for implementing the requirements of the 1972 federal Clean Water Act and the 1999 Florida Watershed Restoration Act (Chapter 99-223, Laws of Florida).

A TMDL represents the maximum amount of a given pollutant that a waterbody can assimilate and still meet the waterbody’s designated uses. A waterbody that does not meet its designated uses is defined as impaired. TMDLs must be developed and implemented for each of the state’s impaired waters, unless the impairment is documented to be a naturally occurring condition that cannot be abated by a TMDL or unless a management plan already in place is expected to correct the problem.

The development and implementation of a Basin Management Action Plan, or BMAP, to reduce the amount of pollutants that caused the impairment will follow this TMDL Report. These activities will depend heavily on the active participation of Orange County, Polk County, Osceola County, the water management district, local governments, local businesses, and other

stakeholders. The Department will work with these organizations and individuals to undertake or continue reductions in the discharge of pollutants and achieve the established TMDLs for the impaired lake.

## Chapter 2: STATEMENT OF WATER QUALITY PROBLEM

---

### 2.1 Legislative and Rulemaking History

Section 303(d) of the federal Clean Water Act requires states to submit to the EPA a list of surface waters that do not meet applicable water quality standards (impaired waters) and establish a TMDL for each pollutant causing the impairment of the listed waters on a schedule. The Department has developed such lists, commonly referred to as 303(d) lists, since 1992. The list of impaired waters in each basin, referred to as the Verified List, is also required by the Florida Watershed Restoration Act, (Subsection 403.067[4]) Florida Statutes [F.S.], and the state's 303(d) list is amended annually to include basin updates.

Lake Kissimmee was included on Florida's 1998 303(d) list. However, the Florida Watershed Restoration Act (FWRA) Section 403.067, F.S., states that all previous Florida 303(d) lists were for planning purposes only and directed the Department to develop, and adopt by rule, a new science-based methodology to identify impaired waters. The Environmental Regulation Commission adopted the new methodology as Chapter 62-303, Florida Administrative Code (F.A.C.) (Identification of Impaired Surface Waters Rule, or IWR), in April 2001 and amended in 2006 and January 2007.

### 2.2 Information on Verified Impairment

The Department used the IWR to assess water quality impairments in Lake Kissimmee. The lake was verified as impaired for nutrients based on an elevated annual average Trophic State Index (TSI) value over the Cycle 1 verification period (the Verified Period for the Cycle 1 Group 4 basins was from January 1, 1998 – June 30, 2005). The impaired condition for nutrients was documented as still present during the Cycle 2 verified period from January 1, 2003 – June 30, 2010. The IWR methodology uses the water quality variables total nitrogen (TN), total phosphorus (TP), and corrected chlorophyll *a* (a measure of algal mass) in calculating annual TSI values and in interpreting Florida's narrative nutrient threshold. For Lake Kissimmee, data were available for the three water quality variables for all four seasons in each year of the Cycle 1 verified period; 1998 – 2005 and for years 2003 – 2009 of the verified period for Cycle 2. In fact such data were available for all ten years included in the model (1997-2006). During Cycle 1, the annual average color of the lake was greater than 40 PCU for each year and the IWR TSI threshold of 60 was exceeded during 1998, 1999, and 2001. During Cycle 2, the annual average color for 2007 was less than 40 PCU (38 PCU) and the TSI threshold of 40 was exceeded (TSI 59) in this year. It should be noted that based on the 40-year period of record, annual average color fell below 40 PCU only twice. Additionally, in Cycle 2, the IWR threshold of 60 (color 57 PCU) was exceeded in 2008 (TSI 64). Per the IWR methodology, exceeding the TSI threshold in any one year of the verified period is sufficient in determining nutrient impairment for a lake.

All data included in **Appendix D** (due to large volume of data, **Appendix D** is published as a separate report) were processed by examining each result for appropriateness. Any results that were rejected are flagged with the remark code xxx. Data reduction followed the procedures in Rule 62-303, F.A.C. Data were further reduced by calculating daily averages. These are the data from which graphs and summary statistics were produced. The annual averages were

calculated from these data by averaging for each calendar quarter and then averaging the four quarters to determine the annual average.

<p>Key to Figure Legends C = results for calibrated/validated Model M&lt; = results for measured data, does not include data from all four quarters M4 = results for measured data, at least one set of data from all four quarters</p>
---

Annual average results for data from outside the combined verified periods (1998 – 2009) are displayed, but were not used in the assessment of impairment. Similarly, any results flagged as M< are displayed, but were not used in the assessment of impairment regardless of the year.

As depicted in **Figures 2.1 and 2.2**, the data for color (true color) show a slight, but not significant, increase over the period of record (1970 -2009). As shown in **Table 2.1**, the color in Lake Kissimmee ranges from just above 12 PCU to nearly 350 PCU with an overall average of 73.7 PCU. The average color for the 5-year period used to calibrate the water quality model was 58 PCU, well below the long-term average. The average color for the 5-year model validation period was 111 PCU, well above the long-term average. The data for alkalinity (1970 – 2009) depicted in **Figure 2.3** and **Table 2.1** show a slight, but not significant, increase over time. The data for pH (1970 – 2010) depicted in **Figure 2.4** and **Table 2.1** show a slight, but not significant, increase over time. The data for Secchi disk depth (1973 – 2010) depicted in **Figure 2.5** and **Table 2.1** show a slight but not significant decrease over time as both the mean and median values of 0.8 meters (m) from the period before 1997 have decreased to 0.7 m for the calibration period and to 0.6 m during the validation period.

Figure 2.1 Daily Average Color (PCU)

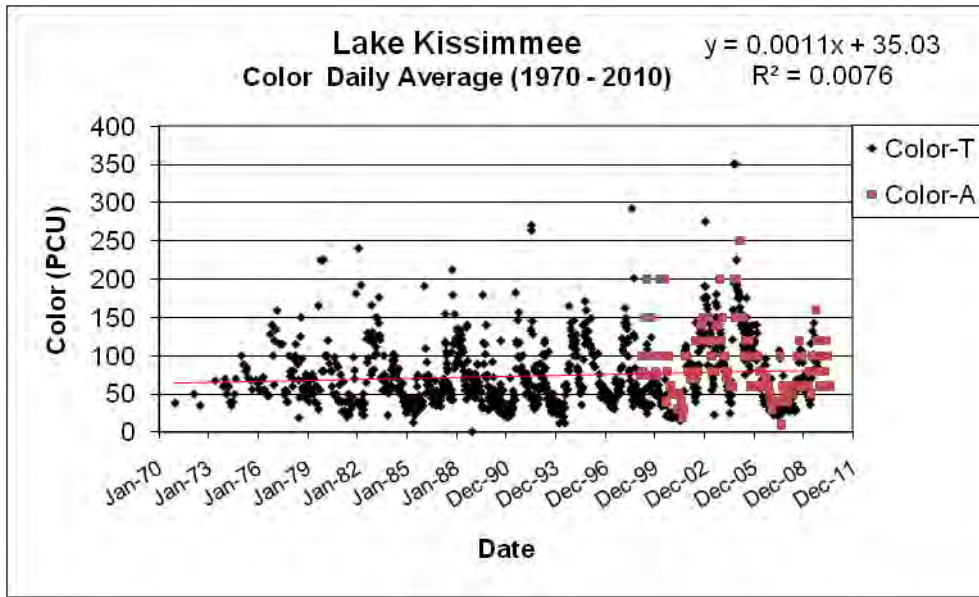


Figure 2.2 Annual Average Color (PCU) 1970 - 2010

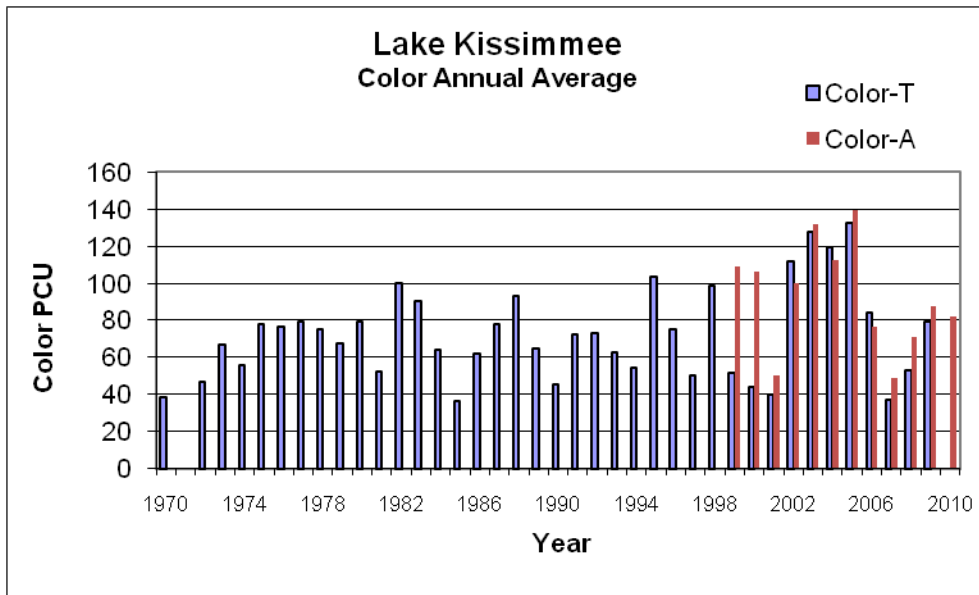


Figure 2.3 Daily Average Alkalinity (mg/L)

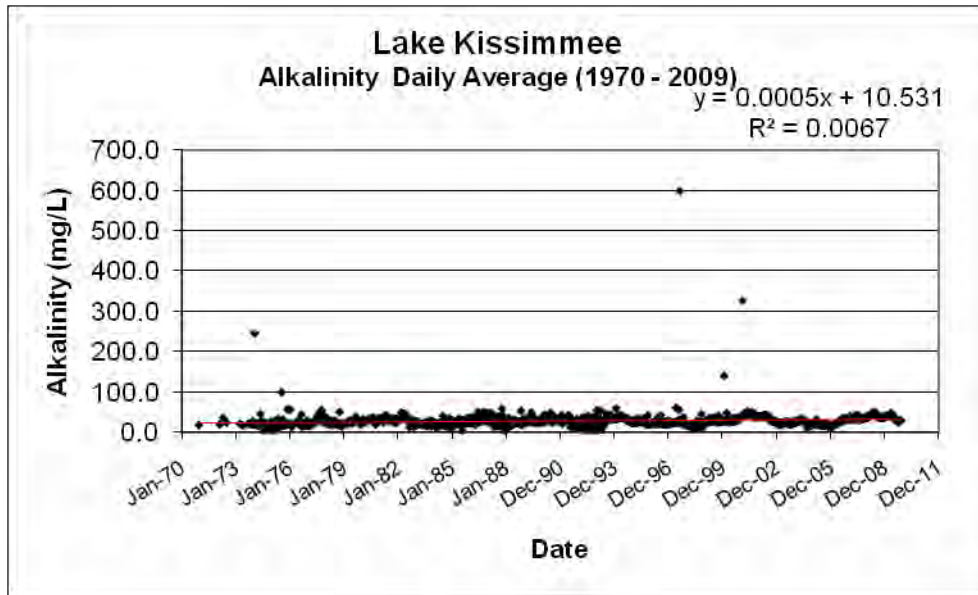


Figure 2.4 Daily Average pH (S.U.)

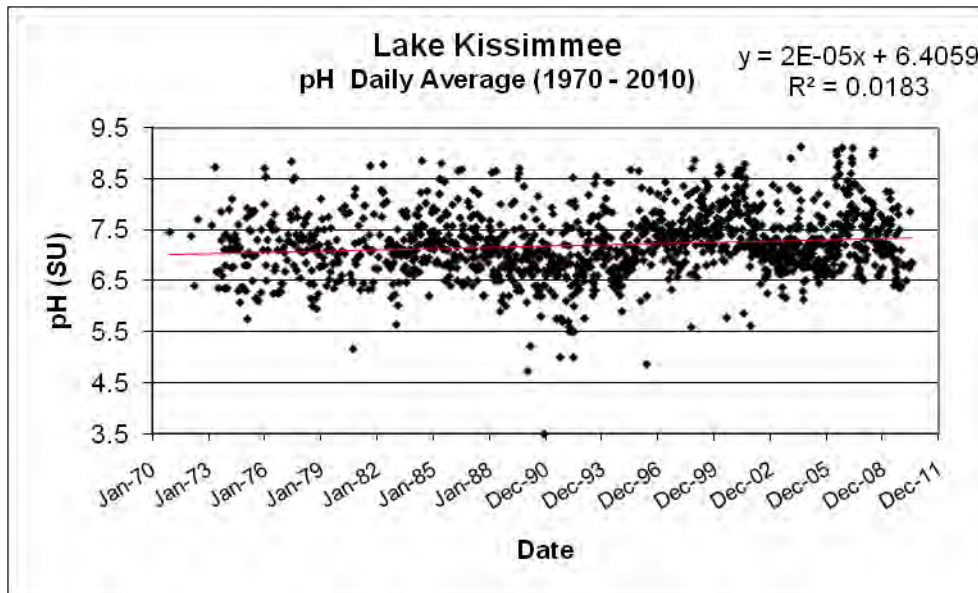
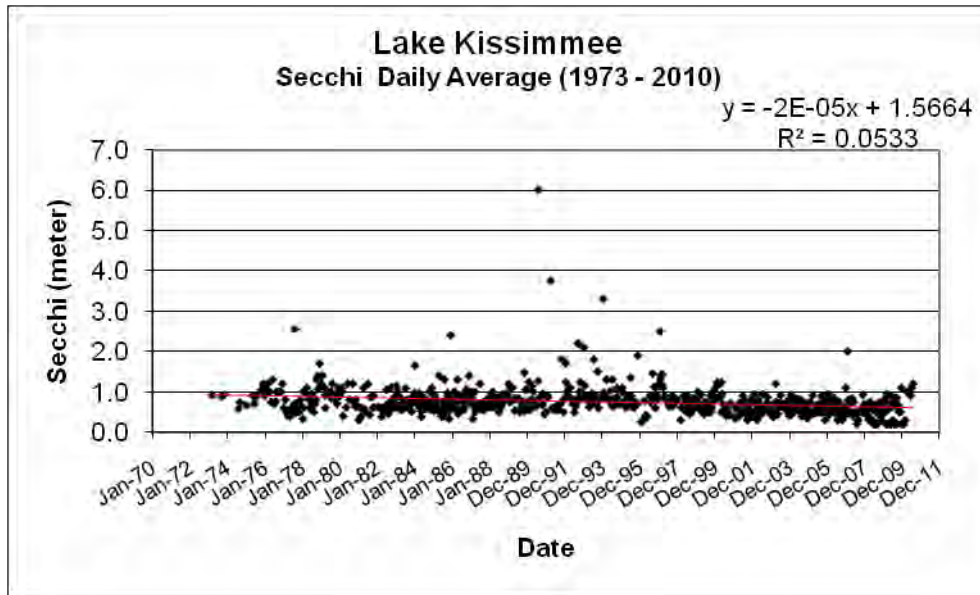


Figure 2.5 Daily Average Secchi (meters)



The TSI is calculated based on concentrations of TP, TN, and corrected chlorophyll a as follows:

$CHLA_{TSI} = 16.8 + 14.4 * LN(Chl\ a)$	Chlorophyll <u>a</u> in $\mu\text{g/L}$
$TN_{TSI} = 56 + 19.8 * LN(N)$	Nitrogen in $\text{mg/L}$
$TN2_{TSI} = 10 * [5.96 + 2.15 * LN(N + 0.0001)]$	Phosphorus in $\text{mg/L}$
$TPTS I = 18.6 * LN(P * 1000) - 18.4$	
$TP2_{TSI} = 10 * [2.36 * LN(P * 1000) - 2.38]$	
<i>If N/P &gt; 30, then <math>NUTR_{TSI} = TP2_{TSI}</math></i>	
<i>If N/P &lt; 10, then <math>NUTR_{TSI} = TN2_{TSI}</math></i>	
<i>if <math>10 &lt; N/P &lt; 30</math>, then <math>NUTR_{TSI} = (TP_{TSI} + TN_{TSI})/2</math></i>	
$TSI = (CHLA_{TSI} + NUTR_{TSI})/2$	Note: TSI has no units

The Hydrologic Simulation Program Fortran (HSPF) model was run for years 1996 – 2006. However, 1996 was used to allow the model to establish antecedent conditions and model comparisons to measured data were only conducted for years 1997 – 2006. For modeling purposes, the analysis of the eutrophication-related data presented in this report for Lake Kissimmee used “all” of the available data from 1997 – 2006 for which records of TP, TN, and corrected chlorophyll a (CChla) were sufficient to calculate seasonal and annual average conditions. However, the data used for the determination of impairment and in the Camp Dresser and McKee (CDM), 2008 report do not contain any LakeWatch data. Additionally, to calculate the TSI for a given year under the IWR, there must be at least one sample of TN, TP, and CChla taken within the same quarter (each season) of the year. For Lake Kissimmee, data was present for at least one of the four seasons in all years (1997-2006).

**Figure 2.6** displays the annual average TSI values for all data from 1975 to 2010 (includes Lakewatch data, whereas the assessment of impairment did not). During the combined verified periods (January 1998 – June 2009) the annual average TSI values exceeded the IWR threshold level of 60 in years 1998 - 2001 and 2004 – 2009, with a mean TSI result of 61.3. While the annual average TSI has declined from the value of 68 reported during 1996, it remains above the IWR threshold value of 60, indicating a need for nutrient reductions.

The daily, annual, and monthly average TN results for Lake Kissimmee from 1970 to 2010 are displayed in **Figures 2.7** through **2.9** and summarized in **Table 2.1**. These data indicate that while the daily and annual average TN results have improved slightly since the mid-1970s through 1988, the mean of 1.31 mg/L for the combined verified periods 1998 – 2009 remains at a level that is expected to be contributing to the elevated TSI results. The monthly average TN results appear highest in April (1.47 mg/L) and lowest during December (1.23 mg/L)

The daily average total ammonia (NH<sub>3</sub>-N) results (1970 – 2010) are displayed in **Figure 2.10** and summarized in **Table 2.1**. These data indicate that while the annual mean (0.043 mg/L) and maximum (0.66 mg/L) NH<sub>3</sub>-N concentration for the period 1970 – 1995 have improved during the period 1996 – 2010 to 0.024 mg/L and 0.28 mg/L, respectively, the concentrations are still in the range that could be contributing to nutrient impairment.

The daily, annual, and monthly average TP results for Lake Kissimmee from 1973 to 2010 are displayed in **Figures 2.11** through **2.13** and summarized in **Table 2.1**. These data indicate a slight increase in TP over time. During the period 1997 – 1999, the lake experienced the highest TP in the data set (1997 and 1999 TP over 0.12 mg/L). The TP averaged 0.108 mg/L during the calibration period (high color) and 0.079 during the validation period (low color). The mean of 0.084 mg/L for the modeled period 1997 – 2006 remains at a level that is expected to be contributing to the elevated TSI results. The monthly average TP results appear highest in late summer and early fall (July – October), averaging 0.89 mg/L and lowest during December through June, averaging 0.071 mg/L.

The daily average ortho-phosphate-P (PO<sub>4</sub>-P) results (1973 – 2008) are displayed in **Figure 2.14** and summarized in **Table 2.1**. These data indicate a slight increase in the PO<sub>4</sub>-P concentrations has occurred over the period of record. **Figure 2.14** depicts two periods between 1988 and 2000 when concentrations were greater than 0.20 mg/L. The overall mean was 0.011 mg/L. The mean during the calibration period was 0.014 mg/L and 0.016 mg/L during the validation period, both means greater than the mean value of 0.009 mg/L for the period before 1997. The pattern and elevated concentrations are supportive of a periodic benthic release of PO<sub>4</sub>-P.

The daily, annual, and monthly average corrected chlorophyll a (CChla) results for Lake Cypress from 1975 to 2010 are displayed in **Figures 2.15** through **2.17** and summarized in **Table 2.1**. These data indicate that while the daily and annual average CChla results have improved slightly since the data collection began, the mean of 38 ug/L for 1996 and 31 ug/L for 2008, taken together with daily average concentrations over 100 ug/L that have occurred during the combined verified periods, is indicative of nutrient enrichment. The mean for the calibration period was 24.1 ug/L and was 19.8 ug/L during the validation period. The monthly average CChla results peak during May – August (average 29.1 ug/L) from a seasonal winter low (December – February) of 20.9 ug/L.

Figure 2.6 TSI Annual Average (1975 – 2010)

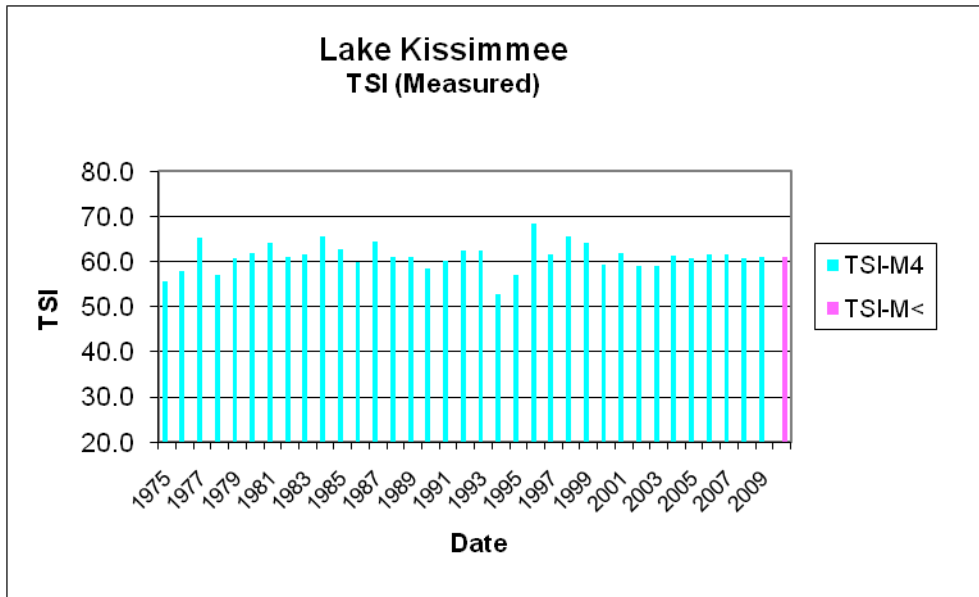
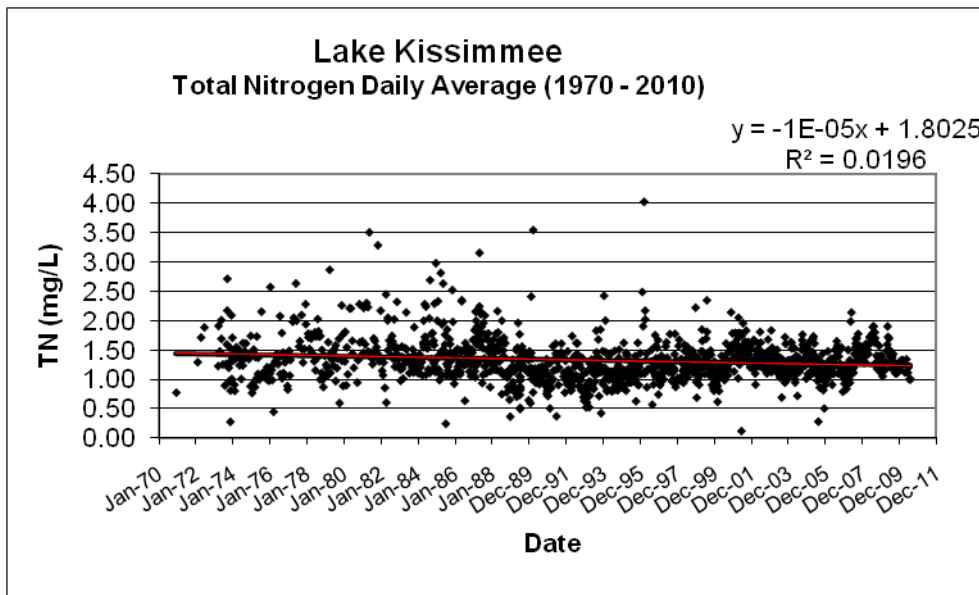
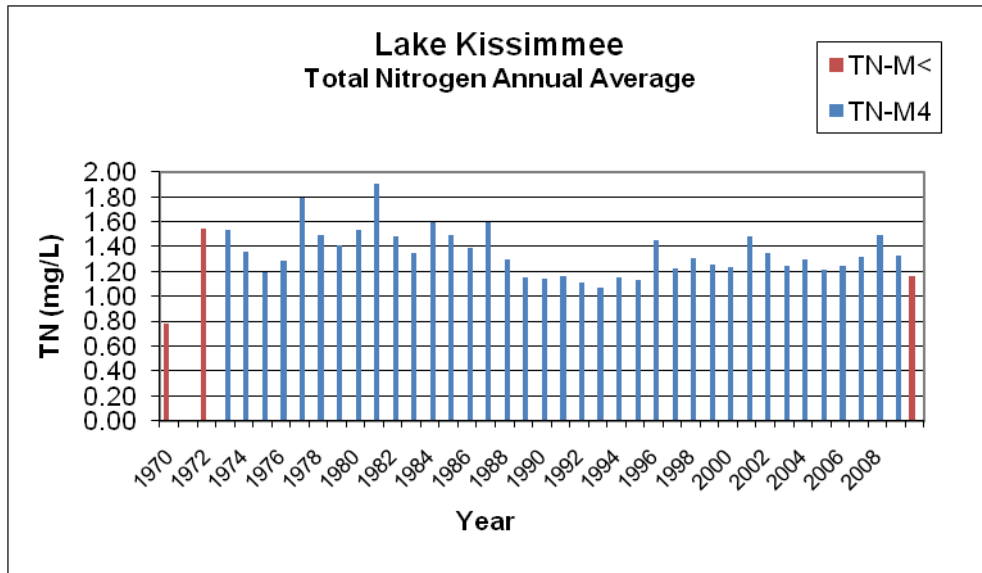


Figure 2.7 Total Nitrogen Daily Average Results



**Figure 2.8 Total Nitrogen Annual Average Results**



**Figure 2.9 Total Nitrogen Monthly Average Results**

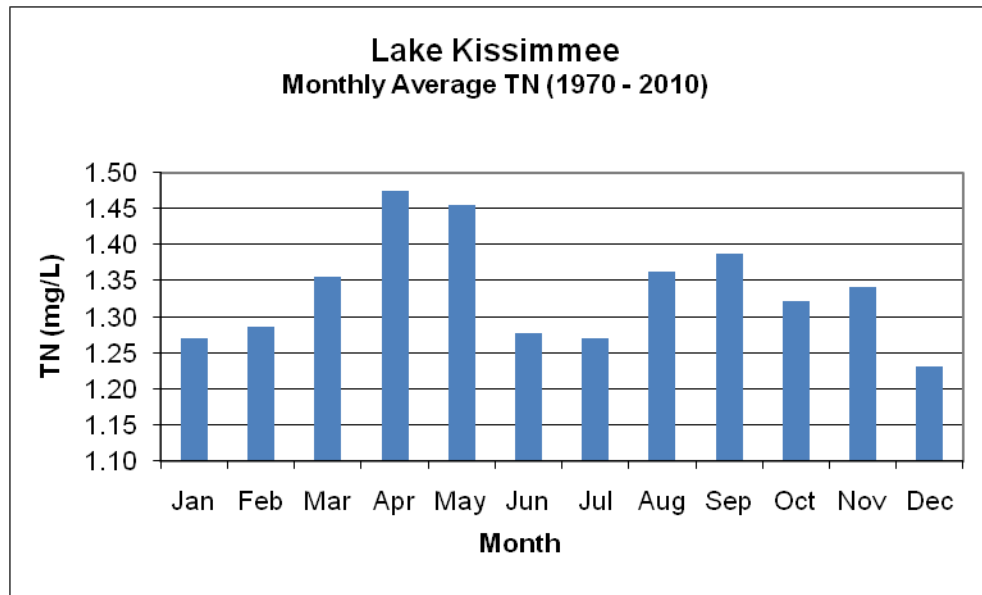


Figure 2.10 Total Ammonia Nitrogen Daily Average Results

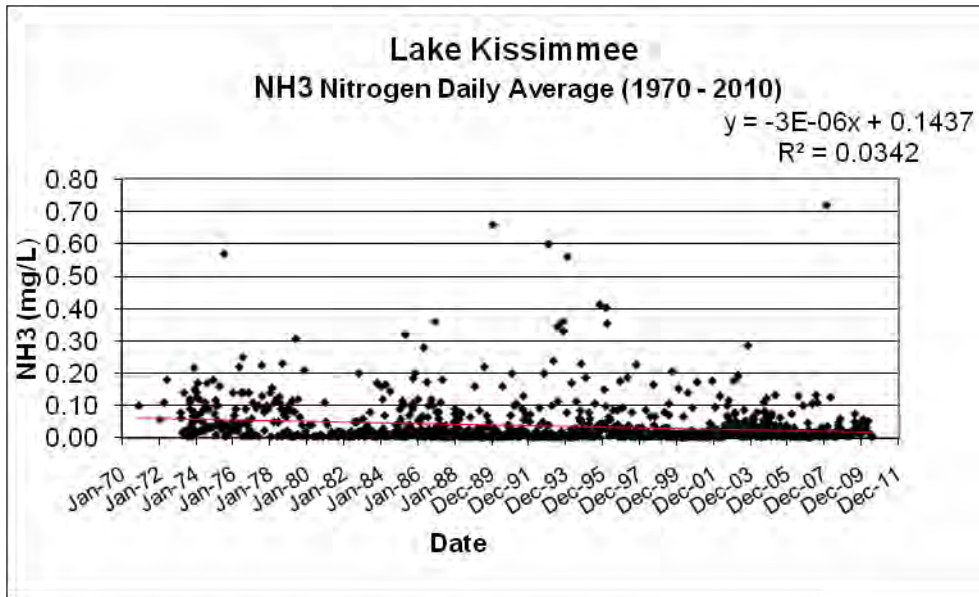
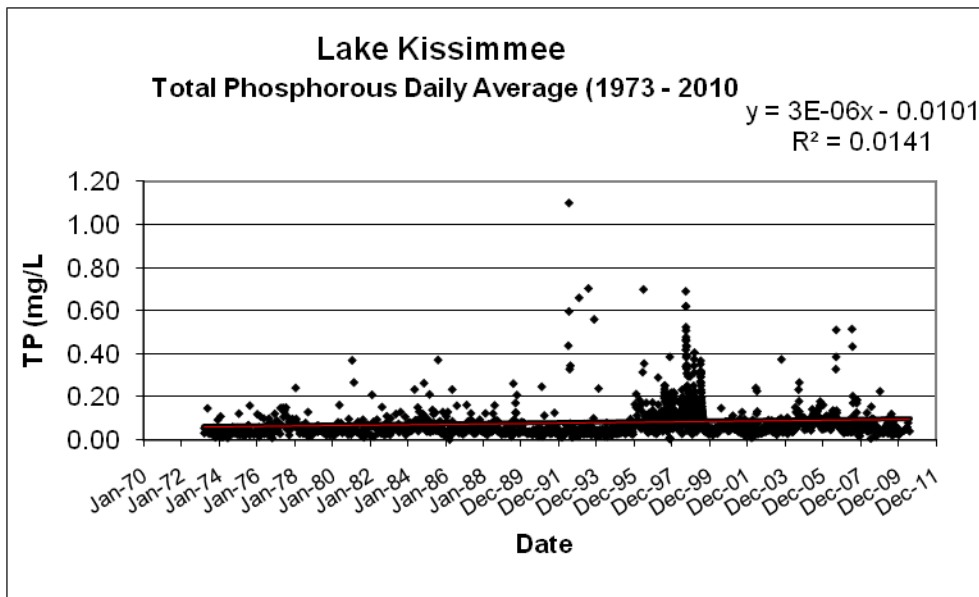
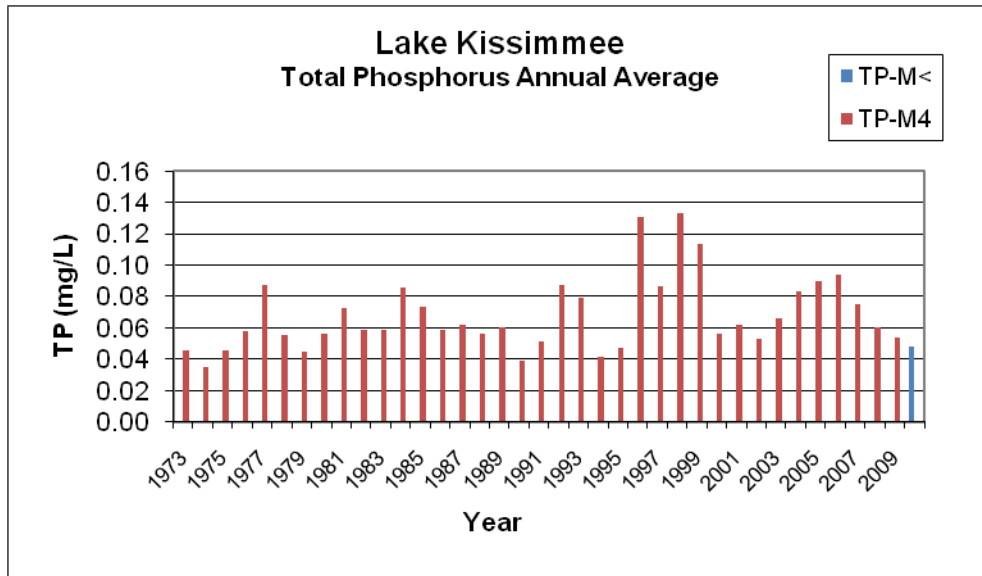


Figure 2.11 Total Phosphorus Daily Average Results



**Figure 2.12 Total Phosphorus Annual Average Results**



**Figure 2.13 Total Phosphorus Monthly Average Results**

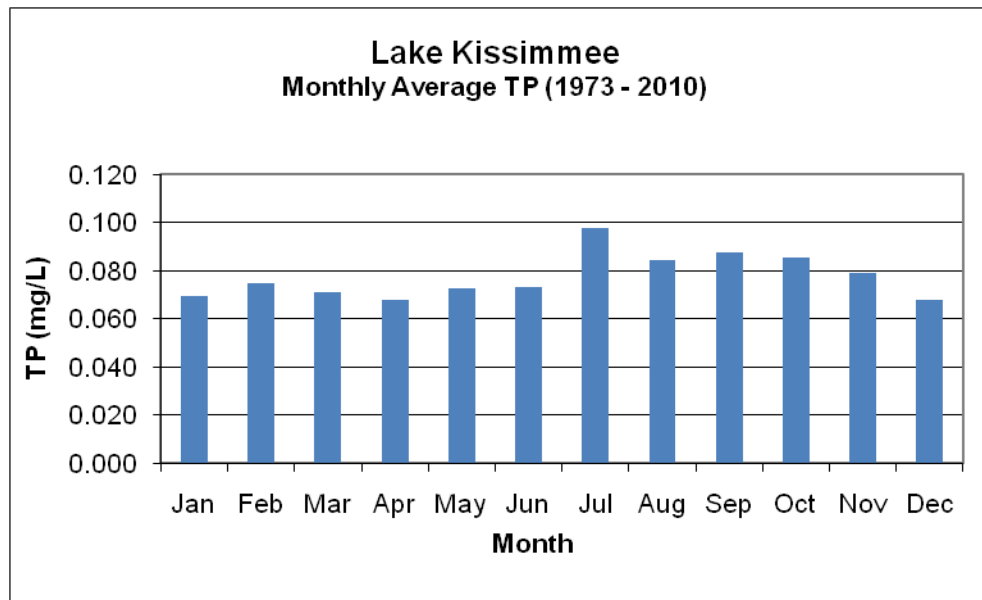


Figure 2.14 Ortho-Phosphate - Phosphorus Daily Average Results

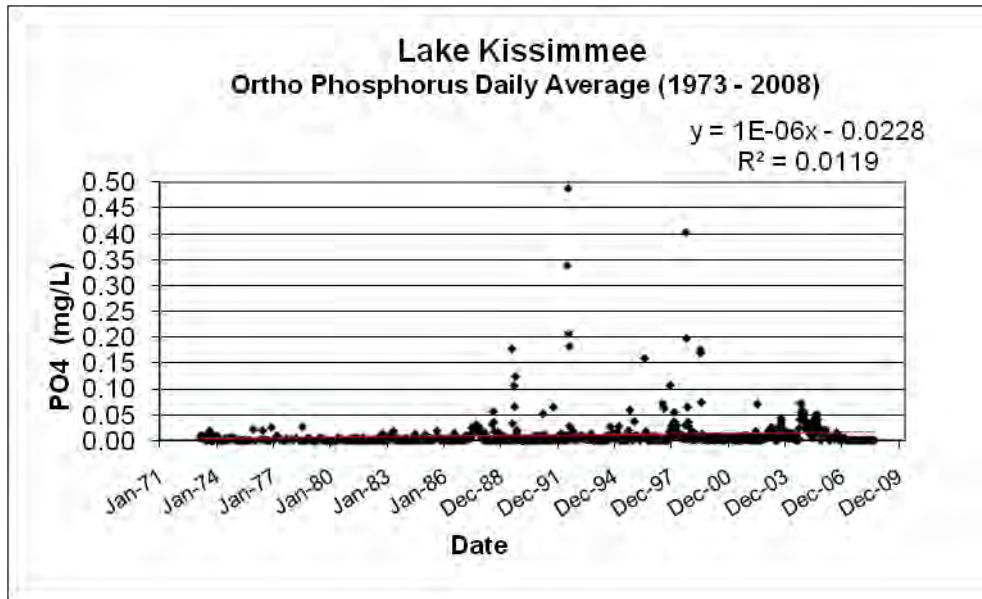


Figure 2.15 Corrected Chlorophyll a Daily Average Results

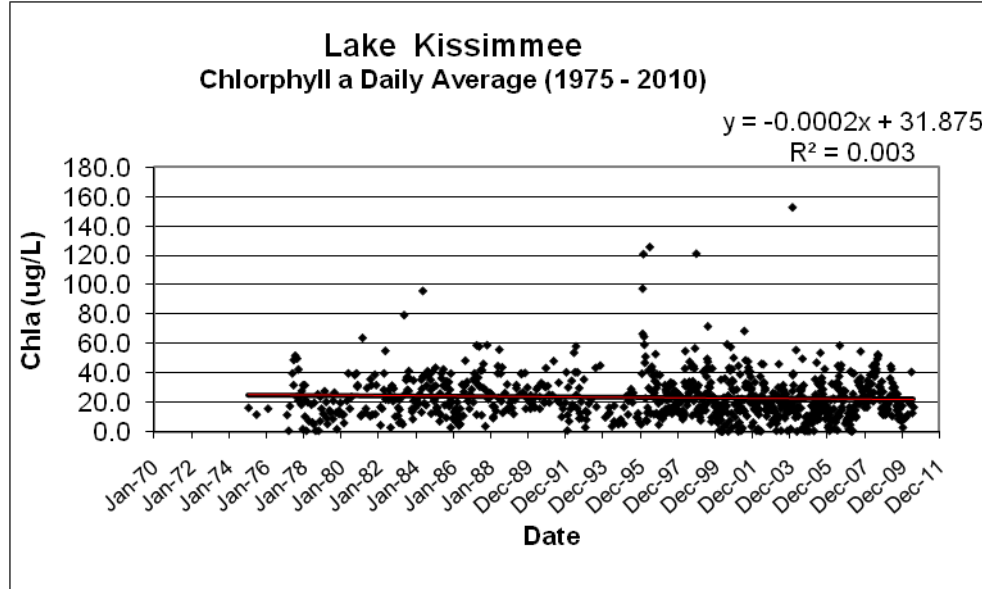


Figure 2.16 Corrected Chlorophyll a Annual Average Results

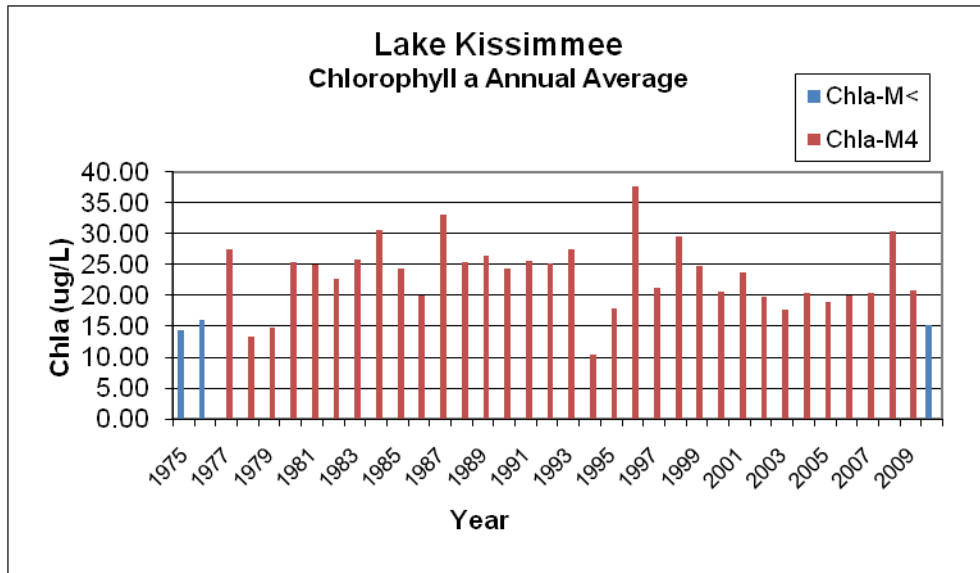
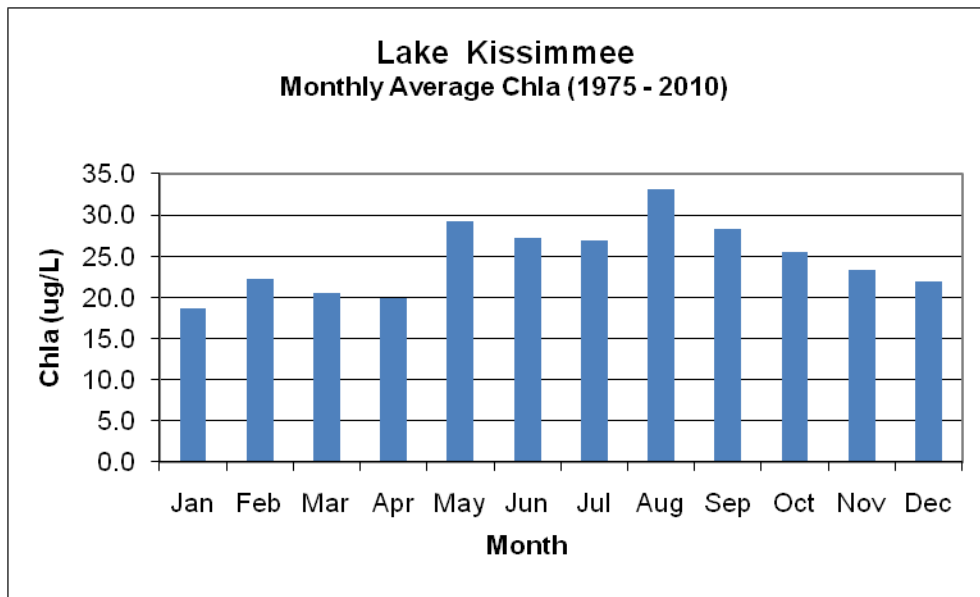


Figure 2.17 Corrected Chlorophyll a Monthly Average Results



**Table 2.1 Water Quality Summary Statistics for TN, NH<sub>3</sub>, NO<sub>2</sub>, TP, PO<sub>4</sub>, Chlorophyll a, Color, Alkalinity, pH, and Secchi**

	Total Nitrogen	NH <sub>3</sub> -N	NO <sub>2</sub> -N	Total Phosphorus	PO <sub>4</sub> -P	Chlorophyll a	Color (true)	Alkalinity	pH	Secchi
	(mg/L)	(mg/L)	(mg/L)	(mg/L)	(mg/L)	(ug/L)	(PCU)	(mg/L)	(SU)	(meter)
Period of Record	1970 - 2010	1970 - 2010	1973 - 2010	1973 - 2010	1973 - 2008	1975 - 2010	1970 - 2009	1970 - 2009	1970 - 2010	1973 - 2010
Count	1385	1289	1200	2576	969	942	1077	1234	1352	732
Minimum	0.13	0.003	0.002	0.002	0.001	0.50	12.0	2.5	3.2	0.2
Mean	1.32	0.035	0.031	0.083	0.011	23.23	73.7	27.6	7.2	0.8
Median	1.28	0.013	0.007	0.067	0.005	21.00	61.0	25.5	7.2	0.7
Maximum	4.02	0.720	0.780	1.100	0.488	153.10	350.0	599.7	9.1	6.0
Pre-calibration	1970-1996	1970-1996	1973-1996	1973-1996	1973-1996	1975-1996	1970-1996	1970-1996	1970-1996	1973-1996
Count	769	708	663	909	571	366	644	746	761	405
Minimum	0.25	0.005	0.002	0.002	0.001	1.00	12.0	2.5	3.5	0.3
Mean	1.33	0.043	0.031	0.065	0.009	24.97	70.7	26.2	7.1	0.8
Median	1.27	0.016	0.010	0.048	0.004	22.19	60.0	25.0	7.1	0.8
Maximum	4.02	0.660	0.780	1.100	0.488	126.10	270.0	245.0	8.9	6.0
Calibration 1997 - 2001										
Count	232	214	195	985	198	209	171	190	194	96
Minimum	0.13	0.004	0.002	0.005	0.002	0.50	15.0	7.1	3.2	0.3
Mean	1.30	0.021	0.014	0.108	0.014	24.10	58.3	32.6	7.5	0.7
Median	1.27	0.010	0.005	0.086	0.006	22.00	48.0	25.7	7.5	0.7
Maximum	2.35	0.227	0.141	0.690	0.403	121.60	292.0	599.7	8.9	2.5
Validation 2002 - 2006										
Count	254	243	225	430	179	237	172	191	254	150
Minimum	0.29	0.005	0.002	0.011	0.001	0.55	23	8.0	6.1	0.3
Mean	1.27	0.027	0.059	0.079	0.016	19.78	111	24.0	7.2	0.6
Median	1.27	0.016	0.020	0.072	0.011	18.00	103	22.0	7.1	0.6
Maximum	1.84	0.287	0.424	0.511	0.074	153.10	350	41.4	9.1	1.2

## Chapter 3. DESCRIPTION OF APPLICABLE WATER QUALITY STANDARDS AND TARGETS

### 3.1 Classification of the Waterbody and Criteria Applicable to the TMDL

Florida's surface water is protected for five designated use classifications, as follows:

<b>Class I</b>	<b>Potable water supplies</b>
<b>Class II</b>	<b>Shellfish propagation or harvesting</b>
<b>Class III</b>	<b>Recreation, propagation, and maintenance of a healthy, well-balanced population of fish and wildlife</b>
<b>Class IV</b>	<b>Agricultural water supplies</b>
<b>Class V</b>	<b>Navigation, utility, and industrial use (there are no state waters currently in this class)</b>

Lake Kissimmee is classified as Class III freshwater waterbody, with a designated use of recreation, propagation and maintenance of a healthy, well-balanced population of fish and wildlife. The Class III water quality criteria applicable to the observed impairment for Lake Kissimmee is the state of Florida's narrative nutrient criterion [Rule 62-302.530(48) (b), FAC].

### 3.2 Interpretation of the Narrative Nutrient Criterion for Lakes

To place a waterbody segment on the Verified List for nutrients, the Department must identify the limiting nutrient or nutrients causing impairment as required by the IWR. The following method is used to identify the limiting nutrient(s) in streams and lakes:

The individual ratios over the entire verified period (i.e., January 1998 to June 2005) were evaluated to determine the limiting nutrient(s). If all the sampling event ratios are less than 10, nitrogen is identified as the limiting nutrient, and if all the ratios are greater than 30, phosphorus is identified as the limiting nutrient. Both nitrogen and phosphorus are identified as limiting nutrients if the ratios are between 10 and 30. For Lake Kissimmee, the mean TN/TP ratio was 18.3 for the verified period (2003-2009), indicating co-limitation of TP and TN for the lake.

Florida's nutrient criterion is narrative only, i.e., nutrient concentrations of a body of water shall not be altered so as to cause an imbalance in natural populations of aquatic flora or fauna. Accordingly, a nutrient-related target was needed to represent levels at which an imbalance in flora or fauna is expected to occur. While the IWR provides a threshold for nutrient impairment for lakes based on annual average TSI levels, these thresholds are not standards and are not required to be used as the nutrient-related water quality target for TMDLs. In recognition that the IWR thresholds were developed using statewide average conditions, the IWR (Subsection 62-303.450, F.A.C.) specifically allows the use of alternative, site-specific thresholds that more accurately reflect conditions beyond which an imbalance in flora or fauna occurs in the waterbody.

The TSI originally developed by R. E. Carlson (1977) was calculated based on Secchi depth, chlorophyll concentration, and total phosphorus concentration and was used to describe a lake's trophic state. Carlson's TSI was developed based on the assumption that the lakes were all phosphorus-limited. In Florida, because the local geology produced a phosphorus rich soil, nitrogen can be the sole or co-limiting factor for phytoplankton population in some lakes. In

addition, because of the existence of dark-water lakes in the state, using Secchi depth as an index to represent lake trophic state can produce misleading results.

Therefore, the TSI was revised to be based on total nitrogen, total phosphorus, and chlorophyll a concentrations. This revised calculation for TSI now contains options for determining a TN - TSI, TP -TSI, and Chlorophyll a -TSI. As a result, there are three different ways of calculating a final in-lake TSI. If the TN to TP ratio is equal to or greater than 30, the lake is considered phosphorus-limited and the final TSI is the average of the TP -TSI and the Chlorophyll a -TSI. If the TN to TP ratio is 10 or less, the lake is considered nitrogen-limited and the final TSI is the average of the TN -TSI and the Chlorophyll a -TSI. If the TN to TP ratio is between 10 and 30, the lake is considered co-limited and the final TSI is the result of averaging the Chlorophyll a - TSI with the average of the TN and TP TSIs.

The Florida-specific TSI was determined based on the analysis of data from 313 Florida lakes. The index was adjusted so that a chlorophyll a concentration of 20 µg/L was equal to a Chlorophyll a -TSI value of 60. The final TSI for any lake may be higher or lower than 60, depending on the TN -TSI and the TP -TSI values. A TSI of 60 was then set as the threshold for nutrient impairment for most lakes (for those with a color higher than 40 platinum cobalt units) because, generally, the phytoplankton may switch to communities dominated by blue-green algae at chlorophyll a levels above 20 µg/L. These blue-green algae are often an unfavorable food source to zooplankton and many other aquatic animals. Some blue-green algae may even produce toxins, which could be harmful to fish and other animals. In addition, excessive growth of phytoplankton and the subsequent death of these algae may consume large quantities of dissolved oxygen and result in anaerobic conditions in lakes, which makes conditions in the impacted lake unfavorable for fish and other wildlife. All of these processes may negatively impact the health and balance of native fauna and flora.

Because of the amazing diversity and productivity of Florida lakes, almost all lakes have a natural background TSI that is different from 60. In recognition of this natural variation, the IWR allows for the use of a lower TSI (40) in very clear lakes, a higher TSI if paleolimnological data indicate the lake was naturally above 60, and the development of site-specific thresholds that better represent the levels at which nutrient impairment occurs.

For the Lake Kissimmee TMDL, the Department applied the HSPF model to simulate water quality discharges and eutrophication processes to determine the appropriate nutrient target. The HSPF model was used to estimate existing conditions in the lake watershed and the background TSI by setting land uses to natural or forested land, and then compare the resulting TSI to the IWR thresholds. If the background TSI can be reliably determined and represents an appropriate target for TMDL development, then an increase of 5 TSI units above background will be used as the water quality target for the TMDL. Otherwise, the IWR threshold TSI of 60 will be established as the target for TMDL development. The HSPF-estimated average background TSI for Lake Kissimmee is 52.8. The model also indicated that in its background condition, the lake was TP-limited in all years, with an average TN/TP ratio of 38.5. This results in a restoration target TSI of 57.8 (background+5) and to the extent practical, a lake that is TP-limited. The development of the Lake Kissimmee TMDL will proceed under the presumption that the TN and TP load reductions proposed for the upstream impaired Lakes Marian, Jackson, and Cypress have been achieved.

### 3.3 Narrative Nutrient Criteria Definitions

#### **Chlorophyll a**

Chlorophyll is a green pigment found in plants and is an essential component in the process of converting light energy into chemical energy. Chlorophyll is capable of channeling the energy of sunlight into chemical energy through the process of photosynthesis. In photosynthesis, the energy absorbed by chlorophyll transforms carbon dioxide and water into carbohydrates and oxygen. The chemical energy stored by photosynthesis in carbohydrates drives biochemical reactions in nearly all living organisms. Thus, chlorophyll is at the center of the photosynthetic oxidation-reduction reaction between carbon dioxide and water.

There are several types of chlorophyll; however, the predominant form is chlorophyll a. The measurement of chlorophyll a in a water sample is a useful indicator of phytoplankton biomass, especially when used in conjunction with analysis concerning algal growth potential and species abundance. Typically, the greater the abundance of chlorophyll a, the greater the abundance of algae. Algae are the primary producers in the aquatic food web, and thus are very important in characterizing the productivity of lakes and streams. As noted earlier, chlorophyll a measurements are also used to estimate the trophic conditions of lakes and lentic waters.

#### **Nitrogen Total as N (TN)**

Total nitrogen is the combined measurement of nitrate ( $\text{NO}_3^-$ ), nitrite ( $\text{NO}_2^-$ ), ammonia, and organic nitrogen found in water. Nitrogen compounds function as important nutrients to many aquatic organisms and are essential to the chemical processes that exist between land, air, and water. The most readily bio-available forms of nitrogen are ammonia and nitrate. These compounds, in conjunction with other nutrients, serve as an important base for primary productivity.

The major sources of excessive amounts of nitrogen in surface water are the effluent from municipal treatment plants and runoff from urban and agricultural sites. When nutrient concentrations consistently exceed natural levels, the resulting nutrient imbalance can cause undesirable changes in a waterbody's biological community and drive an aquatic system into an accelerated rate of eutrophication. Usually, the eutrophication process is observed as a change in the structure of the algal community and includes severe algal blooms that may cover large areas for extended periods. Large algal blooms are generally followed by depletion in dissolved oxygen concentrations as a result of algal decomposition.

#### **Phosphorus Total as P (TP)**

Phosphorus is one of the primary nutrients that regulates algal and macrophyte growth in natural waters, particularly in fresh water. Phosphate, the form in which almost all phosphorus is found in the water column, can enter the aquatic environment in a number of ways. Natural processes transport phosphate to water through atmospheric deposition, ground water percolation, and terrestrial runoff. Municipal treatment plants, industries, agriculture, and domestic activities also contribute to phosphate loading through direct discharge and natural transport mechanisms. The very high levels of phosphorus in some of Florida's streams and estuaries are sometimes linked to phosphate mining and fertilizer processing activities.

High phosphorus concentrations are frequently responsible for accelerating the process of eutrophication, or accelerated aging, of a waterbody. Once phosphorus and other important nutrients enter the ecosystem, they are extremely difficult to remove. They become tied up in biomass or deposited in sediments. Nutrients, particularly phosphates, deposited in sediments generally are redistributed to the water column. This type of cycling compounds the difficulty of halting the eutrophication process.

## Chapter 4: ASSESSMENT OF SOURCES

---

### 4.1 Overview of Modeling Process

The Lake Kissimmee watershed is a part of a larger network of lakes and streams that drain to the Kissimmee River, and ultimately, Lake Okeechobee. As there are several other lakes/streams in the Kissimmee River Basin for which TMDLs are being developed, the Department contracted with CDM to gather all available information and to setup, calibrate, and validate four separate HSPF model projects. See **Appendix B** for modeling details.

HSPF (EPA, 2001 and Brickell *et al.*, 2001) is a comprehensive package that can be used to develop a combined watershed and receiving water model. The external load assessment conducted using HSPF was intended to determine the loading characteristics of the various sources of pollutants to Lake Kissimmee. Assessing the external load entailed assessing land use patterns, soils, topography, hydrography, point sources, service area coverage's, climate, and rainfall to determine the volume, concentration, timing, location, and underlying nature of the point, nonpoint, and atmospheric sources of nutrients to the lake.

The model has the capability of modeling various species of nitrogen and phosphorus, chlorophyll *a*, coliform bacteria, and metals in receiving waters (bacteria and metals can be simulated as a "general" pollutant with potential instream processes including first-order decay and adsorption/desorption with suspended and bed solids). HSPF has been developed and maintained by Aqua Terra and the EPA and is available as part of the EPA supported software package BASINS (Better Assessment Science Integrating point and Nonpoint Sources). The PERLND (pervious land) module performs detailed analyses of surface and subsurface flow for pervious land areas based on the Stanford Watershed Model. Water quality calculations for sediment in pervious land runoff can include sediment detachment during rainfall events and reattachment during dry periods, with potential for washoff during runoff events. For other water quality constituents, runoff water quality can be determined using buildup-washoff algorithms, "potency factors" (e.g., factors relating constituent washoff to sediment washoff), or a combination of both. The IMPLND (impervious land) module performs analysis of surface processes only and uses buildup-washoff algorithms to determine runoff quality. The RCHRES module is used to simulate flow routing and water quality in the receiving waters, which are assumed to be one-dimensional. Receiving water constituents can interact with suspended and bed sediments through soil-water partitioning. HSPF can incorporate "special actions" that utilize user-specified algorithms to account for occurrences such as opening/closing of water control structures to maintain seasonal water stages or other processes beyond the normal scope of the model code.

More information on HSPF / BASINS can be found at [www.epa.gov/waterscience/basins/](http://www.epa.gov/waterscience/basins/).

### 4.2 Potential Sources of Nutrients in the Lake Kissimmee Watershed

An important part of the TMDL analysis is the identification of pollutant source categories, source subcategories, or individual sources of the pollutant of concern in the watershed and the amount of pollutant loading contributed by each of these sources. Sources are broadly classified as either "point sources" or "nonpoint sources." Historically, the term "point sources" has meant discharges to surface waters that typically have a continuous flow via a discernable, confined, and discrete conveyance, such as a pipe. Domestic and industrial wastewater treatment facilities (WWTFs) are examples of traditional point sources. In contrast, the term "nonpoint sources" was used to describe intermittent, rainfall driven, diffuse sources of pollution

associated with everyday human activities, including runoff from urban land uses, agriculture, silviculture, and mining; discharges from failing septic systems; and atmospheric deposition.

However, the 1987 amendments to the Clean Water Act redefined certain nonpoint sources of pollution as point sources subject to regulation under the EPA’s National Pollutant Discharge Elimination Program (NPDES). These nonpoint sources included certain urban stormwater discharges, including those from local government master drainage systems, construction sites over five acres, and a wide variety of industries (see **Appendix A** for background information on the federal and state stormwater programs). To be consistent with Clean Water Act definitions, the term “point source” will be used to describe traditional point sources (such as domestic and industrial wastewater discharges) and stormwater systems requiring an NPDES stormwater permit when allocating pollutant load reductions required by a TMDL. However, the methodologies used to estimate nonpoint source loads do not distinguish between NPDES stormwater discharges and non-NPDES stormwater discharges, and as such, this source assessment section does not make any distinction between the two types of stormwater.

**4.2.1 Point Sources**

There are no permitted wastewater treatment facilities or industrial wastewater facilities that discharge directly to Lake Kissimmee. The facilities listed in **Table 4.1** are within the extended Lake Kissimmee watershed, but were not included in the model as they are not surface water dischargers.

*Table 4.1 NPDES Facilities*

NPDES Permit ID	Facility Name	Receiving Water	Permitted Capacity (mgd)	Downstream Impaired WBID	Comments
FL0036862	Poinciana WWTF #3	None	0.85	Lake Cypress	Discharge to wetlands system; backup to reuse system
FL0039446	TWA/Buenaventura Lakes WWTF	None	1.8	Lake Cypress	Discharge through rapid infiltration basins
FL0168581	Universal Studios-Jaws Lagoon	None	0.05	Lake Cypress	Discharge from stormwater pond
FLA010989	Lake Marian Paradise WWTF	None	0.02	Lake Marian	No surface water discharge

## Municipal Separate Storm Sewer System Permittees

Municipal separate storm sewer systems (MS4s) may discharge nutrients to waterbodies in response to storm events. To address stormwater discharges, the EPA developed the NPDES stormwater permitting program in two phases. Phase I, promulgated in 1990, addresses large and medium MS4s located in incorporated places and counties with populations of 100,000 or more. Phase II permitting began in 2003. Regulated Phase II MS4s, which are defined in Section 62-624.800, F.A.C., typically cover urbanized areas serving jurisdictions with a population of at least 10,000 or discharge into Class I or Class II waters, or Outstanding Florida Waters.

The stormwater collection systems in the Lake Kissimmee watershed, which are owned and operated by Polk County in conjunction with the Florida Department of Transportation (FDOT) District 1, are covered by NPDES Phase I MS4 permit number FLS000015. The collection systems which are owned and operated by Osceola County and the City of St. Cloud, are covered by NPDES Phase II MS4 permit number FLR04E012. The collection system for the City of Orlando is covered by NPDES Phase I permit number FLS000014. The collections systems for Orange County and the City of Belle Isle are covered by NPDES Phase 1 permit number FLS000011. The collection system for the City of Kissimmee is covered by NPDES Phase II permit number FLR04E64. The collection system for the Florida Department of Transportation District 5 is covered by NPDES permit number FLR04E024. The collections systems for the Florida Turnpike are covered by NPDES permit number FLR04E049.

### 4.2.2 Nonpoint Sources and Land Uses

Unlike traditional point source effluent loads, nonpoint source loads enter at so many locations and exhibit such large temporal variation that a direct monitoring approach is often infeasible. For the Lake Kissimmee TMDL, all nonpoint sources were evaluated by use of a watershed and lake modeling approach. Land use coverages in the watershed and sub-basin were aggregated using the Florida Land Use, Cover and Forms Classification System (FLUCCS, 1999) into nine different land use categories. These categories are cropland/improved pasture/tree crops (agriculture), unimproved pasture/woodland pasture (pasture), rangeland/upland forests, commercial/industrial, high density residential (HDR), low density residential (LDR), medium density residential (MDR), water, and wetlands. The spatial distribution and acreage of different land use categories for HSPF were identified using the 2000 land use coverage (scale 1:24,000) provided by the South Florida Water Management District (SFWMD).

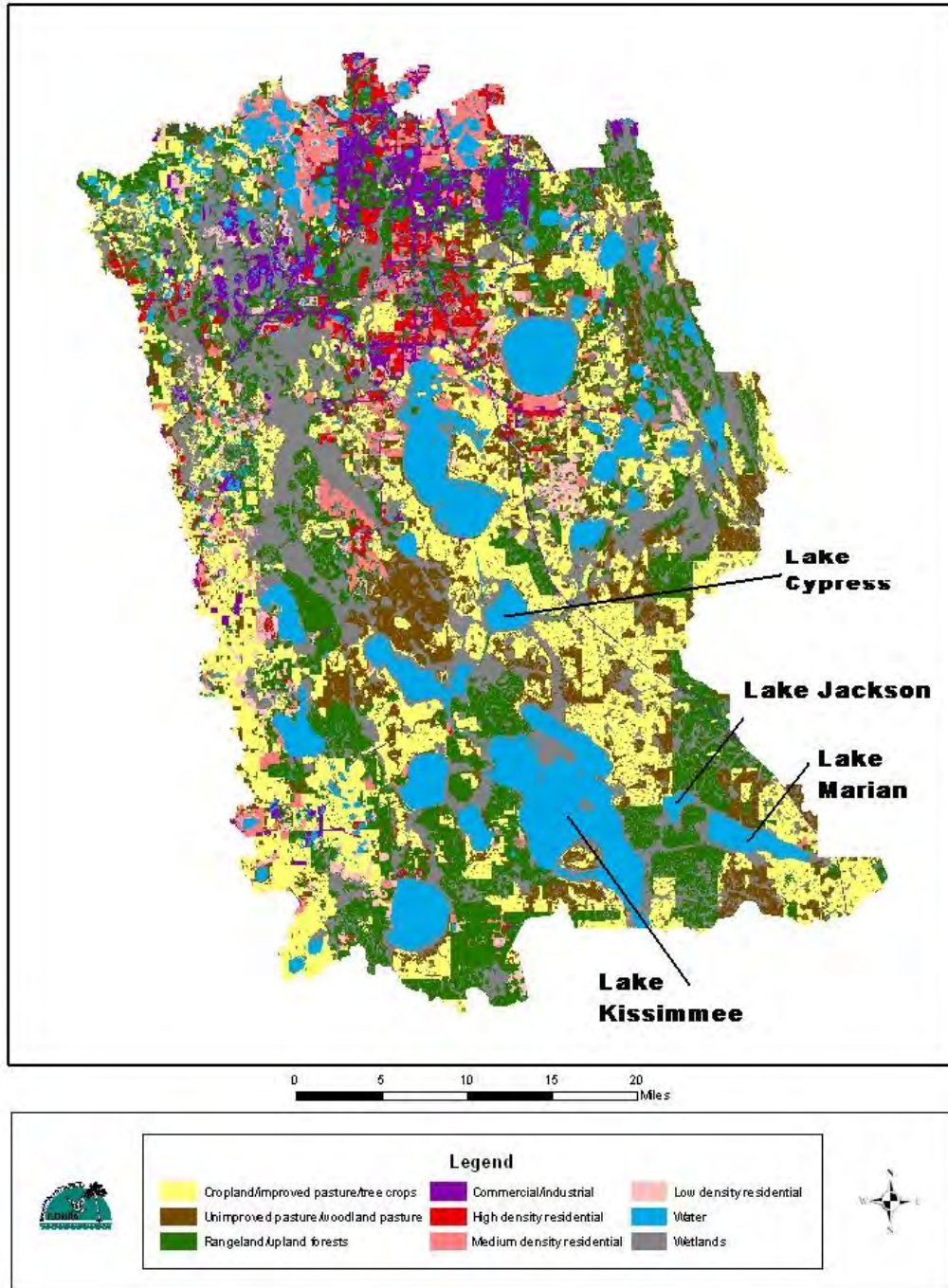
**Table 4.2** shows the existing area of the various land use categories in the extended Lake Kissimmee watershed and the lake sub-basin (surface area of water not included). **Figure 4.1** shows the drainage area of Lake Kissimmee and the spatial distribution of the land uses shown in **Table 4.2**.

The predominant land coverages for the entire Lake Kissimmee extended watershed and lake sub-basin combined include wetland (29.3%), agriculture (24.5%), forest/rangeland (21.5%), pastureland (9.4%), commercial/industrial (4.9%), MDR (4.5%), LDR (3.2%), and HDR (2.7%) respectively.

**Table 4.2 Extended Watershed and Lake sub-basin Existing Land Use Description**

Lake Kissimmee Extended Watershed and Lake sub-basin Existing Land Use Coverage	Extended Watershed		Lake Sub- basin		Total Watershed	
	Acres	Percent	Acres	Percent	Acres	Percent
Agriculture	202,454.0	24.36	18,037.20	25.65	220,491.2	24.46
Wetland	242,163.0	29.13	21,952.40	31.22	264,115.4	29.30
Forest/Rangeland	171,156.0	20.59	22,559.90	32.08	193,715.9	21.49
Pastureland	78,040.0	9.39	7,079.00	10.07	85,119.0	9.44
Commercial/Industrial	43,960.0	5.29	79.80	0.11	44,039.8	4.89
High Density Residential	24,122.0	2.90	38.30	0.05	24,160.3	2.68
Medium Density Residential	40,479.0	4.87	255.20	0.36	40,734.2	4.52
Low Density Residential	28,833.0	3.47	319.10	0.45	29,152.1	3.23
<b>Sum</b>	<b>831,207.0</b>	<b>100.0</b>	<b>70,320.90</b>	<b>100.0</b>	<b>901,527.9</b>	<b>100.0</b>

Figure 4.1 Lake Kissimmee Watershed Existing Land Use Coverage



### Osceola County Population

According to the U.S Census Bureau (U. S. Census Bureau Web site, 2008), the county occupies an area of approximately 1,321.9 square miles (sq mi). The total population in 2000 for Osceola County, which includes (but is not exclusive to) the Lake Kissimmee watershed and sub-basin, was 172,493. The population density in Osceola County, in the year 2000, was at or less than 130.5 people per sq mi. The Bureau estimates the 2006 Osceola County population at 244,045 (185 people/sq mi). For all of Osceola County (2006), the Bureau reported a housing density of 83 houses per sq mi. Osceola County is well below the average housing density for Florida counties of 158 housing units per sq mi.

### Polk County Population

According to the U.S Census Bureau (2008), the county occupies an area of approximately 1,875 sq mi. The total population in 2000 for Polk County, which includes (but is not exclusive to) the Lake Kissimmee watershed and sub-basin, was 483,924. The population density in Polk County, in the year 2000, was at or less than 258.2 people per sq mi. The Bureau estimates the 2006 Polk County population at 561,606 (299 people/sq mi). For all of Polk County (2006), the Bureau reported a housing density of 134 houses per sq mi. Polk County is just below the average housing density for Florida counties of 158 with 134 housing units per sq mi.

### Septic Tanks

Onsite sewage treatment and disposal systems (OSTDSs), including septic tanks, are commonly used where providing central sewer is not cost-effective or practical. When properly sited, designed, constructed, maintained, and operated, OSTDSs are a safe means of disposing of domestic waste. The effluent from a well-functioning OSTDS is comparable to secondarily treated wastewater from a sewage treatment plant. When not functioning properly, however, OSTDSs can be a source of nutrients (nitrogen and phosphorus), pathogens, and other pollutants to both ground water and surface water. Section 2.5.2.1 Septic Tanks, of the CDM, 2008 report describes in detail how septic tanks were included in the HSPF model. In general, the HSPF model does not directly account for the impacts of failing septic tanks. CDM came to the conclusion that failing septic tanks were not believed to have significant impacts on Lake Jackson and therefore not explicitly included in the model, because (a) there is a limited amount of urban land in the study area, (b) failure rates are typically low (10% failing or less), and (c) the amount of urban land believed to be served by septic tanks is also low in the study area.

### Osceola County Septic Tanks

As of 2006, Osceola County had a cumulative registry of 24,148 septic systems. Data for septic tanks are based on 1971 – 2006 census results, with year-by-year additions based on new septic tank construction. The data do not reflect septic tanks that have been removed going back to 1970. From fiscal years 1994–2006, an average of 157.4 permits/year for repairs was issued in Osceola County (Florida Department of Health, 2008). Based on the number of permitted septic tanks estimated for 2006 (24,148) and housing units (109,892) located in the county, approximately 78 percent of the housing units are connected to a central sewer line (i.e., wastewater treatment facility), with the remaining 22 percent utilizing septic tank systems.

### Polk County Septic Tanks

As of 2006, Polk County had a cumulative registry of 115,838 septic systems. Data for septic tanks are based on 1971 – 2006 census results, with year-by-year additions based on new septic tank construction. The data do not reflect septic tanks that have been removed going back to 1970. From fiscal years 1994–2006, an average of 1246 permits/year for repairs was issued in Polk County (Florida Department of Health, 2008). Based on the estimated number of permitted septic tanks (115,838) and housing units (269,410) located in the county, approximately 57 percent of the housing units are estimated as connected to a central sewer line (i.e., wastewater treatment facility), with the remaining 43 percent estimated as utilizing septic tank systems. **Table 4.3** contains the percent area of septic tanks used for each model basin.

**Table 4.3 Septic Tank Coverage for Urban Land Uses**

Receiving Water	HSPF Model Reach	Septic Tank Coverage (%)			
		Commercial	HDR	LDR	MDR
Reedy Creek	100	14	1	30	7
Lake Speer	110	3	0	25	57
Lake Tibet & Sheen	120	2	13	32	15
Clear Lake	130	10	10	1	4
Lake Conway	140	7	9	23	17
Reedy Creek	150	9	2	20	9
Reedy Creek	160	10	10	9	17
Big Sand Lake	170	2	5	27	12
Shingle Creek	180	7	3	28	10
Boggy Creek	190	22	3	0	3
Boggy Creek	200	15	5	2	11
Reedy Creek	210	1	5	22	5
Shingle Creek	220	8	3	19	20
Shingle Creek	230	56	1	9	25
City Ditch Canal	240	29	3	0	7
Shingle Creek	250	11	3	31	25
Shingle Creek	260	10	17	15	19
Boggy Creek	270	0	0	29	21
Lake Myrtle	280	0	0	32	6
Lake Hart	290	9	0	17	16
East Lake Tohopekaliga	300	14	1	25	15
Lake Tohopekaliga	310	9	7	35	16
Alligator Lake	320	17	17	34	26
Lake Marion	330	18	2	22	12
Lake Marion Creek	340	23	3	15	8
Reedy Creek	350	8	1	4	4
Lake Gentry	360	0	0	0	0
S-63A	370	0	0	0	0
Cypress Lake	380	0	10	0	0
Lake Jackson	460	0	0	0	0
Lake Marian	450	0	99	21	22

<sup>1</sup> Septic tank coverage estimated based on available septic tank and sewer service area information.

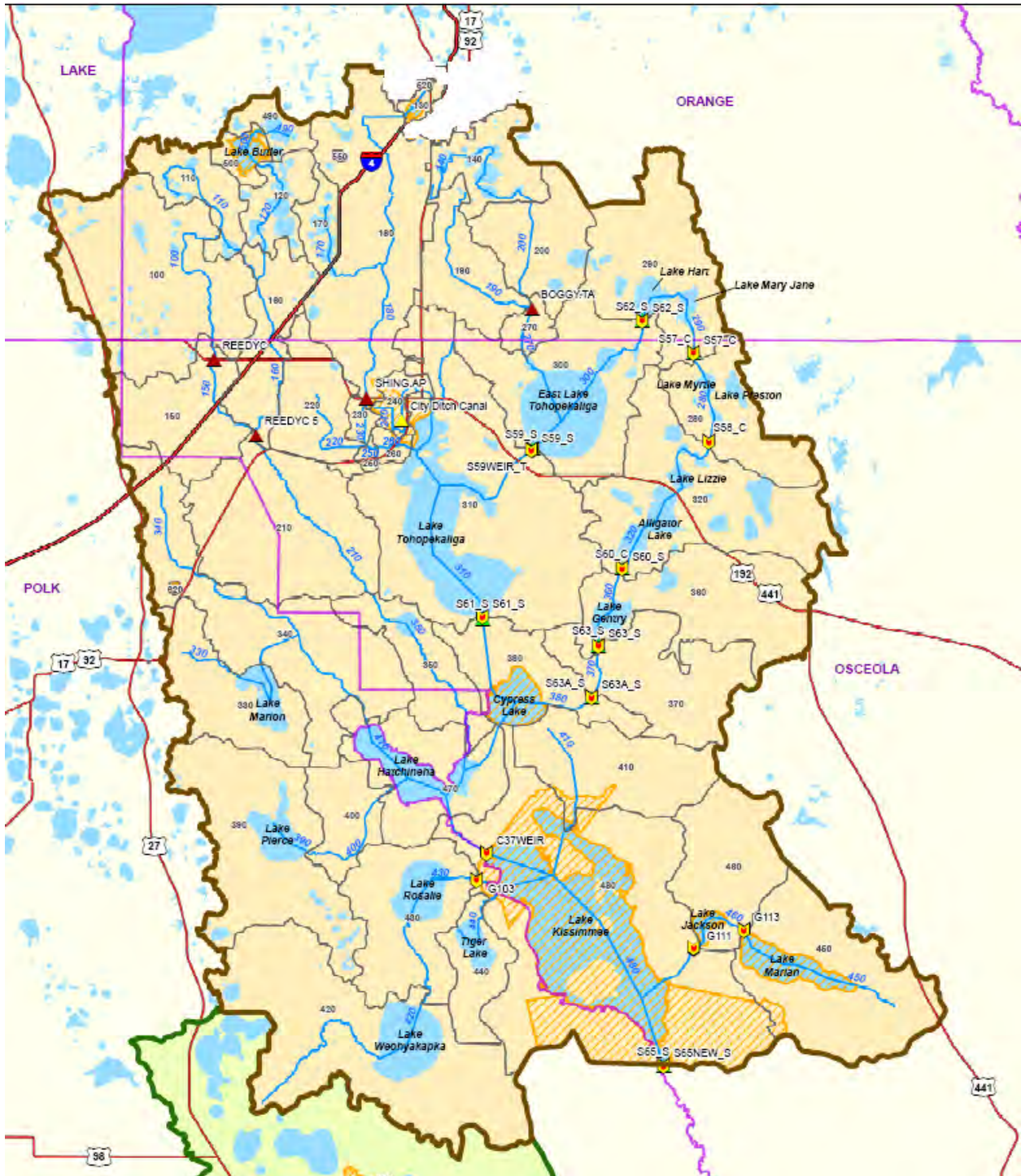
### 4.3 Estimating Point and Nonpoint Source Loadings

#### Model Approach

The HSPF model was utilized to estimate the nutrient loads within and discharged from the Lake Kissimmee Basin. The HSPF model allows the Department to interactively simulate and assess the environmental effects of various land use changes and associated land use practices. The model was run for 1996 through 2006. The year 1996 was used to establish antecedent conditions (model spin-up). Model calibration was performed for January 1997 through December 2001 and model validation was performed for January 2002 through December 2006. All measured data and model result comparisons are for years 1997 through 2006.

The water quality parameters (impact parameters) simulated within the model for Lake Kissimmee include: water quantity (surface runoff, interflow and baseflow), and water quality (total nitrogen, organic nitrogen, ammonia nitrogen, NOX nitrogen, total phosphorus, organic phosphorus, ortho-phosphorus, phytoplankton as biologically active chlorophyll *a* (corrected), temperature, total suspended solids, dissolved oxygen, and ultimate carbonaceous biological oxygen demand). Data sets of land use, soils, topography and depressions, hydrography, USGS gage and flow data, septic tanks, water use pumpage, point sources, ground water, atmospheric deposition, solar radiation, control structures, and rainfall (CDM 2008) are used to calculate the combined impact of the watershed characteristics for a given modeled area on a waterbody represented in the model as a reach. **Figure 4.2** depicts the model's basins, reaches, and control structures. The waterbodies on the figure that are cross-hatched represent areas of special interest (waters on the 1998 303(d) list).

Figure 4.2 Lake Kissimmee (Reach 480) HSPF Modeled Watershed Flow Routing and Reach Numbers



## IMPLND Module for Impervious Tributary Area

The IMPLND module of HSPF accounts for surface runoff from impervious land areas (e.g., parking lots and highways). For the purposes of this model, each land use was assigned a typical percentage of directly connected impervious area (DCIA), as shown in **Table 4.4** based on published values (CDM, 2002). Four of the nine land uses contain some impervious areas.

**Table 4.4 Percentage of Impervious Area**

Land Use Category	% DCIA
1. Commercial / Industrial	80
2. Cropland / Improved pasture / Tree crops	0
3. High density residential	50
4. Low density residential	10
5. Medium density residential	25
6. Rangeland / Upland Forests	0
7. Unimproved pasture / Woodland pasture	0
8. Wetlands	0
9. Water	0

Note: Most of the water and wetland land uses in the system are modeled as a “reach” in HSPF.

## PERLND Module for Pervious Tributary Area

The PERLND module of HSPF accounts for surface runoff, interflow, and ground water flow (baseflow) from pervious land areas. For the purposes of modeling, the total amount of pervious tributary area was estimated as the total tributary area minus the impervious area.

HSPF uses the Stanford Watershed Model methodology as the basis for hydrologic calculations. This methodology calculates soil moisture and flow of water between a number of different storages, including surface storage, interflow storage, upper soil storage zone, a lower soil storage zone, an active ground water zone, and deep storage. Rain that is not converted to surface runoff or interflow infiltrates into the soil storage zones. The infiltrated water is lost by evapotranspiration, discharged as baseflow, or lost to deep percolation (e.g., deep aquifer recharge). In the HSPF model, water and wetlands land uses were generally modeled as pervious land (PERLND) elements. Since these land use types are expected to generate more flow as surface runoff than other pervious lands, the PERLND elements representing water and wetlands were assigned lower values for infiltration rate (INFILT), upper zone nominal storage (UZSN), and lower zone nominal storage (LZSN).

Hydrology for large waterbodies (e.g., lakes) and rivers and streams that connect numerous lakes throughout the Project Area were modeled in RCHRES rather than PERLND (see Section 4.3.1.3 of the CDM, 2008 report). For each sub-basin containing a main stem reach, a number of acres were removed from the water land use in PERLND, which were modeled explicitly in RCHRES. The acres removed from these sub-basins correspond to the areas of the lakes and the streams. In the reaches representing these waterbodies, HSPF accounted for direct rainfall on the water surface and direct evaporation from the water surface.

Several of the key parameters adjusted in the analysis include the following:

- LZSN (lower zone nominal storage) - LZSN is the key parameter in establishing an annual water balance. Increasing the value of LZSN increases the amount of infiltrated water that is lost by evapotranspiration and, therefore, decreases the annual stream flow volume.
- LZETP (lower zone evapotranspiration parameter) – LZETP affects the amount of potential evapotranspiration that can be satisfied by lower zone storage and is another key factor in the annual water balance.
- INFILT (infiltration) - INFILT can also affect the annual water balance. Increasing the value of INFILT decreases surface runoff and interflow, increases the flow of water to the lower soil storage and ground water, and results in greater evapotranspiration.
- UZSN (upper zone nominal storage) - Reducing the value of UZSN increases the percentage of flow that is associated with surface runoff, as opposed to ground water flow. This would be appropriate for areas where receiving water inflows are highly responsive to rainfall events. Increasing UZSN can also affect the annual water balance by resulting in greater overall evapotranspiration.

### RCHRES Module for Stream/Lake Routing

The RCHRES module of HSPF conveys flows input from the PERLND and IMPLND modules, accounts for direct water surface inflow (rainfall) and direct water surface outflow (evaporation), and routes flows based on a rating curve supplied by the modeler. Within each sub-basin of each planning unit model, a RCHRES element was developed, which defines the depth-area-volume relationship for the modeled waterbody.

The depth-area-volume relationships for Lake Alligator, Lake Myrtle, Lake Hart, Lake Gentry, Lake East Tohopekaliga, Lake Tohopekaliga, Lake Cypress, Lake Hatchineha, and Lake Kissimmee in the Upper Kissimmee Planning Unit were obtained from the *Upper Kissimmee Chain of Lakes Routing Model, Appendix B* (PBSJ, XPSofWare, and SFWMD, 2001). For all other major lakes and the impaired WBIDs in the Project Area, the stage-area-volume relationships were developed based on the lake's bathymetry data. Section 4.2.10 of the CDM, 2008 report provides more detailed information of how the lake bathymetry data were used to develop the depth-area-volume relationships.

For the lakes with hydraulic control structures, the design discharge rates were used in the depth-area-volume-discharge relationships once the lake stages were one foot or more than the target levels. When the lake stages were between 0 and 1 foot above the targets, the flows were assumed to vary linearly between zero (0 foot above target) and the design flows (1 foot above target).

As discussed in Section 4.2.11 of the CDM, 2008 report, the depth-area-volume relationships for the reaches in the Upper Kissimmee Planning Unit were developed based on the cross-section data extracted from the other models.

An initial Manning's roughness coefficient value of 0.035, typical for natural rivers and streams, was used in flow calculations. In some instances, the roughness coefficient value was adjusted during the model calibrations to reflect local conditions, such as smaller values for well-maintained canals and bigger values for meandering, highly vegetated, and not well-defined

streams. The slopes of water surface (S) were approximated with the reach bottom slopes, which were estimated based on the Digital Elevation Model data.

### Implementation of Hydraulic Control Structure Regulation Schedules

In order to simulate the hydraulic control structure regulation schedules in the HSPF models, the stages were approximated with step functions as described in detail in Section 4 of the CDM, 2008 report. Variable step functions were used to approximate different regulation schedules. In each approximation, a step function was defined such that stage variations generally equaled one foot. In several instances, however, stage variations were less than one foot or less than 1.5 feet due to the stage variations in the original regulation schedules. For each hydraulic control structure, a sequential dataset was created to mimic the regulation schedules. Sequential datasets in this HSPF modeling application define the discharge column to evaluate from the FTABLE.

An FTABLE is a table in the HSPF model input file that summarizes the geometric and hydraulic properties of a reach. Normally, an FTABLE has at least 3 columns: depth, surface area, and volume. For the FTABLE associated with a reach with a control structure, columns 4 through 8 can be used to define control structure operation flow rates for different operation zones. For example, the approximated operation schedule for a given lake may have four operation zones (1 through 4). For each year from January 1<sup>st</sup> to April 5<sup>th</sup> (zone 1), the sequential dataset instructs the HSPF model to use the discharge rate in Column 4 in the FTABLE. Similarly, Columns 5, 6, 7 in the FTABLE are used as the operation schedule progresses into Zones 2, 3, and 4, respectively.

Based on discussions with operations staff, actual operations often did not follow the regulation schedules due to various reasons; therefore, an accurate match between the measured stages and flows and those simulated were not expected. Instead, annual water and nutrient budgets for each impaired WBID were the focus.

### Lake Kissimmee Existing Land Use Loadings

The HSPF simulation of pervious lands (PERLNDs) and impervious lands (IMPLNDs) calculates hourly values of runoff from pervious and impervious land areas, and interflow and baseflow from pervious lands, plus loads of water quality constituents associated with these flows. For PERLNDs, TSS (sediment) was simulated in HSPF by accounting for sediment detachment caused by rainfall, and subsequent washoff of the detached sediment when surface runoff occurs. Loads of other constituents in PERLND runoff were calculated in the GQUAL (general quality constituent) model of HSPF, using a “potency factor” approach (*i.e.*, defining how many pounds of constituent are washed off per ton of sediment washed off).

One exception occurs for (DO), which HSPF evaluates at the saturation DO concentration in surface runoff. For PERLNDs, concentrations of constituents in baseflow were assigned based on typical values observed in several tributaries in the study area such as Boggy Creek and Reedy Creek, and interflow concentration were set at values between the estimated runoff and baseflow concentrations. For IMPLNDs, TSS (sediment) is simulated by a “buildup-washoff” approach (buildup during dry periods, washoff with runoff during storm events) and again the “potency factor” approach was used in the IQUAL module for other constituents except DO, which again was analyzed at saturation.

The “general” water quality constituents that were modeled in HSPF include the following:

- Ammonia Nitrogen;

- Nitrate Nitrogen;
- CBOD (ultimate);
- Ortho-Phosphate; and
- Refractory Organic Nitrogen.

One feature of HSPF is that the CBOD concentration has associated concentrations of organic-N and organic-P. Consequently, the TN concentration is equal to the sum of ammonia-N, nitrate-N, refractory organic-N, and a fraction of the CBOD concentration. Similarly, the TP concentration is equal to the sum of ortho-P and a fraction of the CBOD concentration.

The total loadings of nitrogen and phosphorus for Lake Kissimmee were estimated using the HSPF model. Modeling frameworks were designed to simulate the period 1996 through 2006. The model year 1996 was used to establish antecedent conditions, the model results are summarized for years 1997 – 2006. This period is inclusive of the Cycle 1 and most of the Cycle 2 verified periods for the Group 4 waterbodies located in the Kissimmee River Basin.

## Chapter 5: DETERMINATION OF ASSIMILATIVE CAPACITY

### 5.1 Determination of Loading Capacity

Nutrient enrichment and the resulting problems related to eutrophication tend to be widespread and are frequently manifested far (in both time and space) from their source. Addressing eutrophication involves relating water quality and biological effects (such as photosynthesis, decomposition, and nutrient recycling), as acted upon by hydrodynamic factors (including flow, wind, tide, and salinity) to the timing and magnitude of constituent loads supplied from various categories of pollution sources. The assimilative capacity should be related to some specific hydro-meteorological condition such as an 'average' during a selected time span or to cover some range of expected variation in these conditions.

As discussed in Chapter 4, the HSPF model was selected as the watershed and waterbody model. It was run dynamically through the ten-year period (1997-2006) on an hourly time step.

#### 5.1.1 Climatology

Rainfall, air temperature, wind speed and direction, solar radiation, cloud cover, relative humidity, evaporation, and dew point temperature directly influence the hydrologic balance and receiving water quality within a watershed. Automatic measuring stations, situated in various locations within the watershed, quantify the climatological data to allow for modeling or other analysis. Spatial and temporal distributions of climatological data are important factors in accurately modeling hydrologic flow conditions within the watershed. As a result, these data are perhaps the most important inputs to the hydrologic and water quality models (CDM, 2008).

#### Rainfall

Rainfall is the predominant factor contributing to the hydrologic balance of a watershed. It is the primary source of surface runoff and baseflow from the watershed to the receiving waters, as well as a direct contributor to the surface of receiving waters. The FDEP maintains a rainfall dataset that combines radar observations from NOAA's National Weather Service Weather Surveillance Radar 88 Doppler (WSR-88Ds) and hourly rainfall observations from an operational *in situ* rain gauge network. The rainfall data were extracted for the Project Area for use in the model.

The FDEP multisensor rainfall dataset was checked against (and supplemented by) the hourly rainfall data obtained from the SFWMD for 51 rainfall stations located within Glades, Highlands, Okeechobee, Osceola, Orange, and Polk Counties. The data collected from these stations range from January 1991 to December 2006. **Table 5.1** provides a summary of these stations along with the maximum intensity recorded at each station. **Figure 5.1** illustrates each station location that is near Lake Kissimmee. The CDM, 2008 report contains additional information and describes how the data were used in the model. **Figure 5.2** depicts the daily rainfall. As can be seen on this figure, the period 2003-2005 contained days with rainfall totals of over 4 inches. **Figure 5.3** shows the monthly average rainfall. Based on this information, August through November is the wet period, averaging over 4 inches, while the months of December through July average just over 3 inches of rainfall. **Figure 5.4** depicts the annual average rainfall for the years 1996-2006. During this period, the average rainfall was 45.4 inches/year. The years 1996, 1997, 1999, 2002, and 2003 are average rainfall years. The years 1998, 2000, 2001, and 2006 are dry years, while 2004 and 2005 are wet years. The 10-year period used to

develop the TMDL (1997 – 2006) included 4 average rainfall years, 4 dry years, and 2 wet years.

**Table 5.1 Hourly Rainfall Stations**

Station	Location (County)	Period of Record		Max. Intensity (in/hr)
		Begin	End	
ALL2R	Osceola	02/19/1998	12/31/2006	2.38
ARS_B0_R	Okeechobee	10/06/1992	12/31/2006	3.29
BASING_R	Okeechobee	11/20/2003	12/31/2006	1.49
BASSETT_R	Okeechobee	06/30/1992	12/31/2006	4.18
BEELINE_R	Orange	04/12/2006	12/31/2006	1.45
CREEK_R	Polk	12/12/2002	12/31/2006	2.72
ELMAX_R	Osceola	08/08/2006	12/31/2006	1.80
EXOTR	Osceola	02/11/1998	12/31/2006	2.88
FLYGW_R	Okeechobee	02/22/2000	12/31/2006	2.63
FLYING_G_R	Okeechobee	01/01/1991	12/31/2006	1.79
GRIFFITH_R	Okeechobee	07/08/2004	12/31/2006	2.26
INDIAN_L_R	Polk	01/25/2003	12/31/2006	1.89
INRCTY_R	Osceola	03/05/2003	12/31/2006	2.32
KENANS1_R	Osceola	12/14/2004	12/31/2006	2.95
KIRCOF_R	Osceola	08/09/2000	12/31/2006	2.55
KISSFS_R	Osceola	07/04/2002	12/31/2006	2.82
KRBNR	Highlands	05/15/1997	12/31/2006	2.69
KREFR	Polk	05/16/1997	12/31/2006	2.69
LOTELA_R	Highlands	12/02/2004	12/31/2006	1.87
MAXCEY_N_R	Osceola	06/20/2006	12/31/2006	1.96
MAXCEY_S_R	Okeechobee	08/04/2006	12/31/2006	1.07
MCARTH_R	Highlands	05/26/2006	12/31/2006	1.14
MOBLEY_R	Okeechobee	09/03/1992	12/31/2006	3.30
OPAL_R	Okeechobee	10/23/1992	12/31/2006	3.21
PC61_R	Okeechobee	04/17/2002	12/31/2006	2.08
PEAVINE_R	Okeechobee	07/05/2004	12/31/2006	4.12
PINE_ISL_R	Osceola	07/21/2004	12/31/2006	2.34
ROCK_K_R	Okeechobee	11/23/2003	12/31/2006	3.06
RUCKGW_R	Okeechobee	02/22/2000	12/31/2006	2.59
RUCKSWF_R	Okeechobee	01/01/1991	12/31/2006	4.73
S59_R	Osceola	12/26/1995	12/31/2006	2.91
S61W	Osceola	10/20/1992	12/31/2006	2.92
S65A_R	Polk	01/30/2003	11/05/2004	1.91
S65C_R	Okeechobee	01/01/1991	11/12/1991	1.41
S65CW	Okeechobee	10/20/1992	12/31/2006	3.45

**Table 5.1 SFWMD Hourly Rainfall Stations (Cont.)**

Station	Location (County)	Period of Record		Max. Intensity (in/hr)
		Begin	End	
S65D_R	Okeechobee	02/23/1995	04/02/2002	2.37
S65DWX	Okeechobee	02/23/2000	12/31/2006	2.44
S68_R	Highlands	03/18/1997	12/31/2006	2.71
S75_R	Glades	03/18/1997	12/31/2006	2.69
S75WX	Glades	09/01/2002	12/31/2006	4.02
S82_R	Highlands	03/18/1997	12/31/2006	1.93
S83_R	Highlands	03/18/1997	12/31/2006	2.87
SEBRNG_R	Highlands	11/30/2004	12/31/2006	1.57
SHING.RG	Orange	03/12/1992	12/31/2006	3.16
SNIVELY_R	Polk	07/14/2004	12/31/2006	1.86
TAYLC_R	Okeechobee	09/18/1995	12/31/2006	8.10
TICK_ISL_R	Polk	01/16/2001	12/31/2006	2.43
TOHO2_R	Osceola	06/25/1996	12/31/2006	2.82
TOHO10_R	Osceola	06/24/1999	12/31/2006	2.50
TOHO15_R	Osceola	07/02/1999	12/31/2006	2.39
WRWX	Polk	04/16/1997	12/31/2006	3.04

Figure 5.1 Hourly Rainfall Stations Lake Kissimmee Watershed

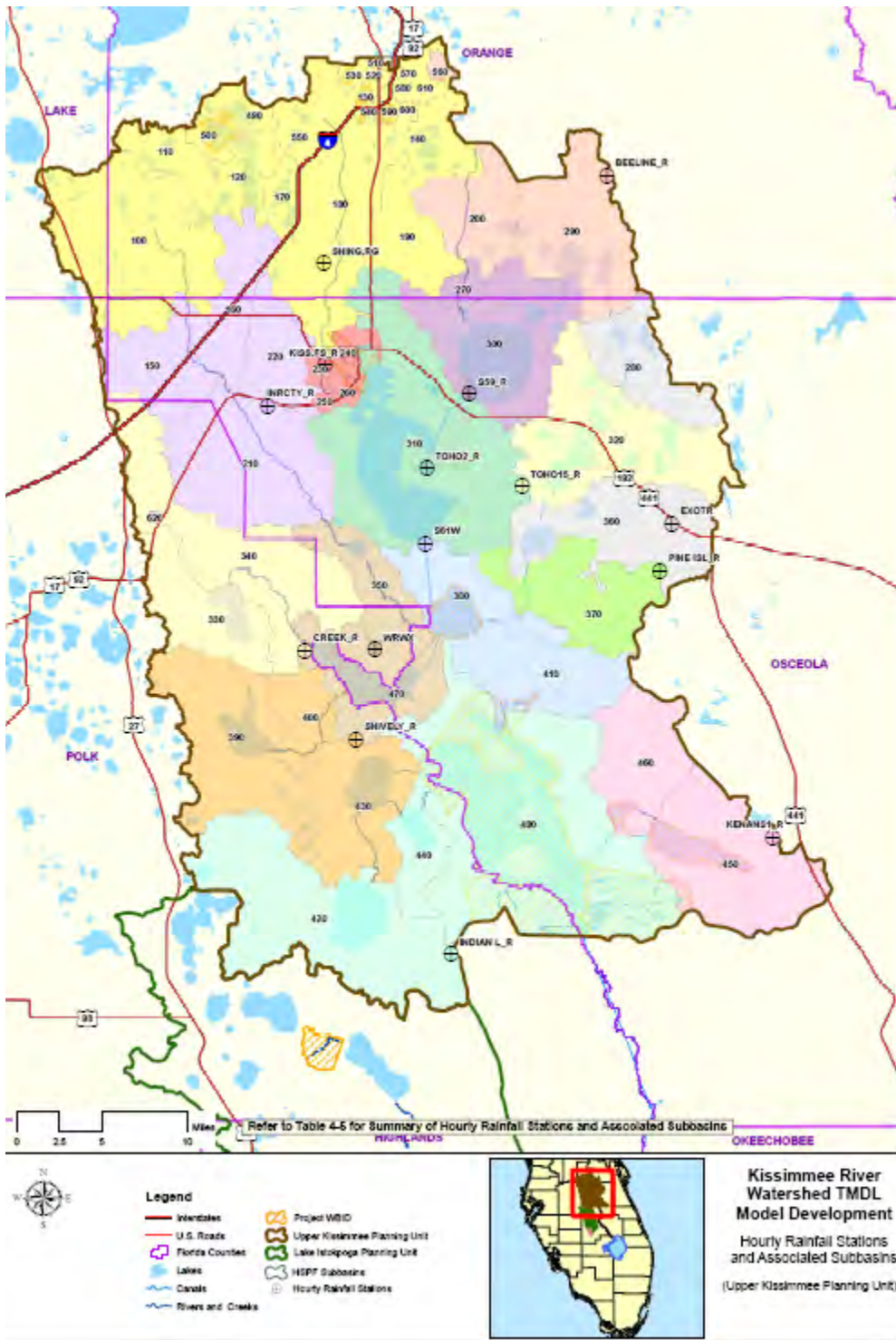


Figure 5.2 Daily Rainfall used in model (1996-2006)

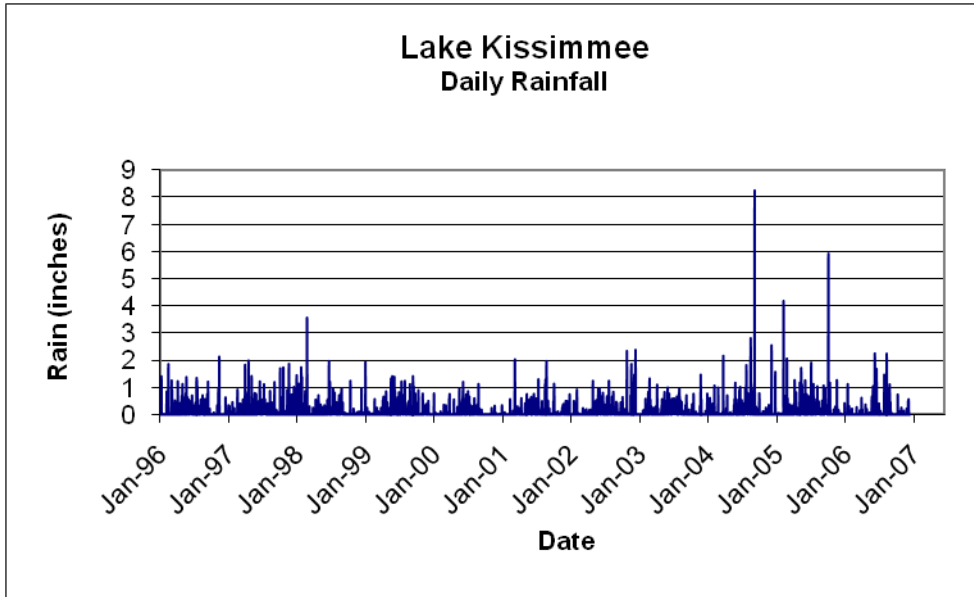
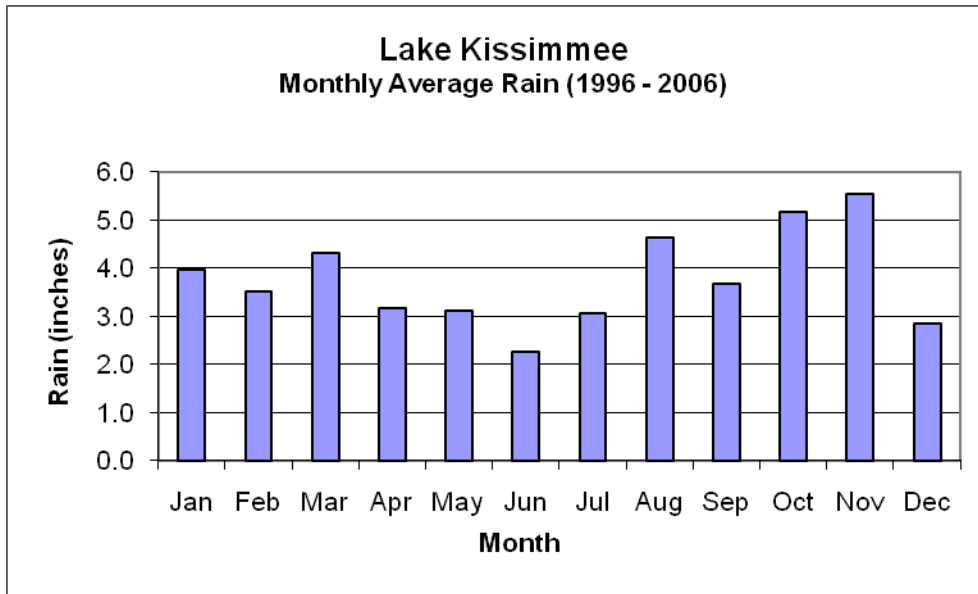
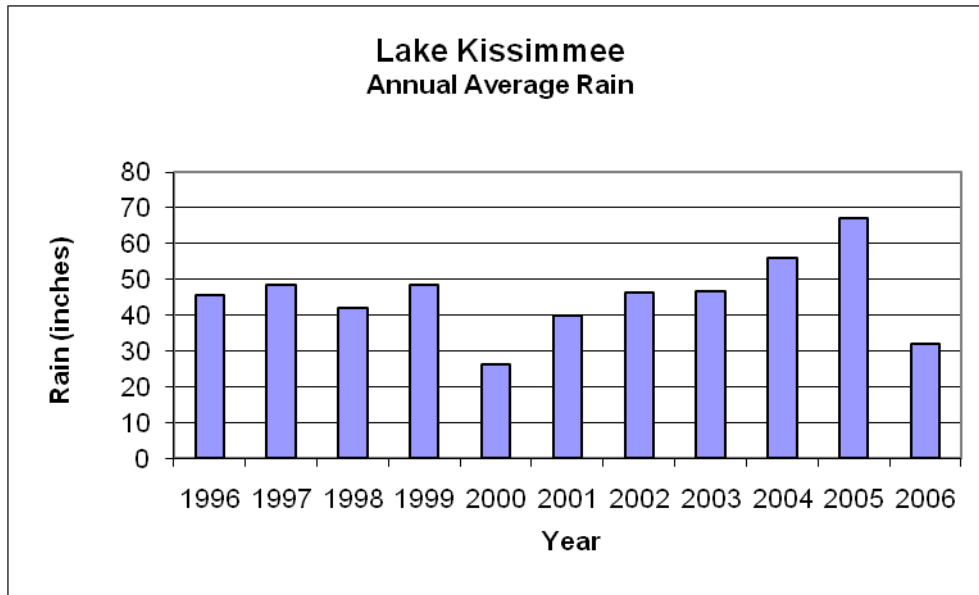


Figure 5.3 Monthly Average Rainfall from Model dataset



**Figure 5.4 Annual Average Rainfall from Model dataset (1996-2006)**

### Evaporation/Evapotranspiration

Evaporation data and evapotranspiration (ET) rates are important factors in developing hydrologic balances and modeling, since they provide estimates of hydrologic losses from land surfaces and waterbodies within the watershed. As a result, daily Class A pan evaporation data and potential ET data were obtained from 14 monitoring stations located within Okeechobee, Osceola, and Polk Counties. The data were downloaded from the SFWMD database DBHYDRO, and the monitoring dates range from January 1991 to December 2006 (**Table 5.2**). **Figure 5.5** illustrates the two station locations closest to the Lake Kissimmee watershed. The CDM, 2008 report contains additional information and describes how the data were used in the model.



**Table 5.2 SFWMD Pan Evaporation and Potential Evapotranspiration Monitoring Stations**

Station	Period of Record		Data Type
	Begin	End	
ARCHBO 2	01/01/1991	11/30/1994	Pan Evaporation
BIRPMWS	01/01/1998	12/31/2006	Potential Evapotranspiration
BIRPSW	01/01/2002	12/31/2006	Potential Evapotranspiration
BIRPWS2	01/01/2002	12/31/2006	Potential Evapotranspiration
EVP376NE	05/01/2005	12/31/2006	Pan Evaporation
KISS.FS_E	01/01/1991	04/30/1999	Pan Evaporation
L ALF EX_E	01/01/1991	11/30/1998	Pan Evaporation
OKEE FIE_E	01/01/1991	04/30/2005	Pan Evaporation
S65C_E	01/01/1991	09/13/1992	Pan Evaporation
S65CW	10/21/1992	12/31/2006	Potential Evapotranspiration
S65DWX	02/23/2000	12/31/2006	Potential Evapotranspiration
S65_E	01/01/1991	12/31/2006	Pan Evaporation
S75WX	09/02/2002	12/31/2006	Potential Evapotranspiration
WRWX	04/17/1997	12/31/2006	Potential Evapotranspiration

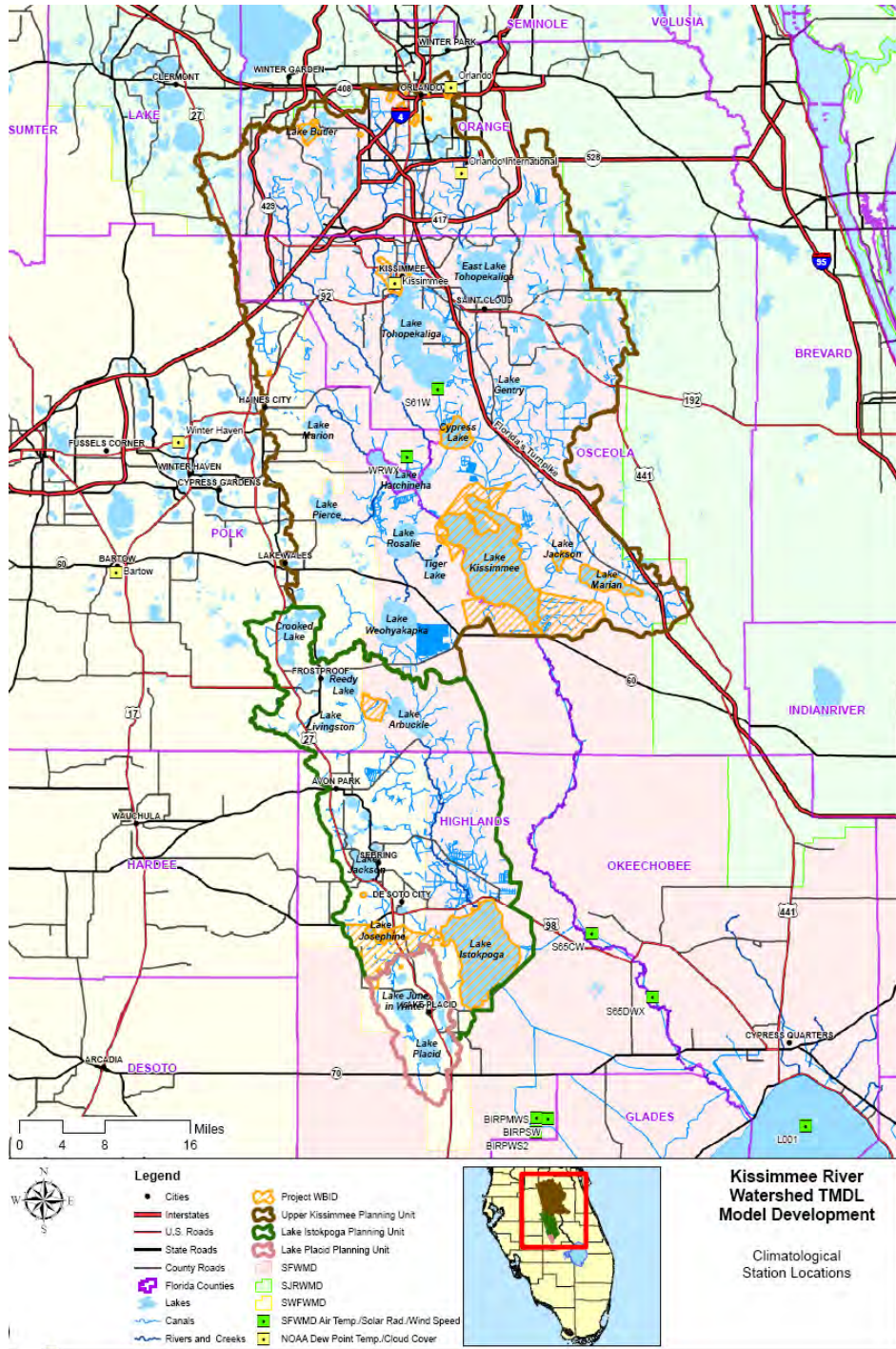
**Other Climatological Data**

Daily air temperature, solar radiation, and wind speed data were obtained from eight monitoring stations located within Okeechobee, Osceola, and Polk Counties, as summarized in **Table 5.3** and shown on **Figure 5.6**. The data were downloaded from DBHYDRO and range from October 1992 to December 2006. Daily cloud cover and dew point temperature data from five monitoring stations were obtained from NOAA.

**Table 5.3 SFWMD Air Temperature, Solar Radiation, and Wind Speed Monitoring Stations**

Station	Period of Record	
	Begin	End
BIRPMWS	01/01/1998	12/31/2006
BIRPSW	01/01/2002	12/31/2006
BIRPWS2	01/01/2002	12/31/2006
L001	08/04/1994	12/31/2006
S61W	10/20/1992	12/31/2006
S65CW	10/20/1992	12/31/2006
S65DWX	02/23/2000	12/31/2006
WRWX	04/17/1997	12/31/2006

Figure 5.6 SFWMD Air Temperature, Solar Radiation, and Wind Speed Monitoring Stations



## 5.2 Model Calibration/Validation

### Hydrologic Calibration/Validation

The HSPF model for the Lake Kissimmee watershed was calibrated using the simulation period of January 1997 through December 2001, with rainfall representing three dry and two average years. Model validation (years 2002-2006) was used to apply the calibrated model to a different time period without changing the calibrated hydrologic and hydraulic parameters. This step is taken to further confirm that those calibrated hydrologic parameters are still applicable to the new time period of model application and statistically similar results are expected. The rainfall during the model validation period included two average, two wet, and one dry year. The full year of 1996 simulation was used as the model start-up (initialization) period, which was not used in the comparison between measured and simulated stream flows and lake stages. Instead, this was considered as an antecedent period for the model to generate reasonable values of soil moisture storage that were not heavily dependent upon the initial model conditions.

Because the study area is largely pervious land, the calibration process focused on the development of appropriate pervious area hydrologic parameters. Initial parameter values were determined based on previous modeling efforts (CDM, 2003). Values were then adjusted to improve the match between measured and modeled stream flows. Parameter values were largely maintained within a range of possible values based on CDM's previous experience with the HSPF hydrologic model and on BASINS Technical Note 6 [Hartigan, 1983 (A); Hartigan, 1983 (B); NVPDC, 1983; NVPDC, 1986; CDM, 2002; EPA, 2000].

Besides the 16 major hydraulic control structures discussed in Section 4.2.5 of the CDM, 2008 report, many local small hydraulic control structures throughout the Reedy Creek and Boggy Creek watersheds in the Upper Kissimmee Planning Unit were identified by other studies (URS Greiner, 1998 and USGS, 2002). It appeared that flow stations with a considerable amount of flow measurements in the Project Area were somewhat affected by the hydraulic control structures. Ideally, flow stations with a considerable amount of flow measurements that are not affected by any hydraulic control structures should be selected for initial hydrological model calibrations. To minimize the effect of hydraulic control structures, the initial calibration focused on three gauged sub-basins in the northern part of the study area in the Upper Kissimmee Planning Unit (Reedy Creek, Shingle Creek, and Boggy Creek), which are not largely influenced by hydraulic control structures. Parameters were established for these sub-basins, which provided a reasonable match to measured data. These parameter values and relationships to land use were then uniformly applied to all the sub-basins in the planning units. Furthermore, sub-basin-specific parameters such as LZSN, UZSN, and INFILT were developed based on local hydrologic soil group information.

Further flow calibrations at the control structures were completed by adjusting control structure flow rates and lake volumes, when appropriate. A detailed discussion of this method is included in Section 4.5 of the CDM, 2008 report.

Additionally, significant ground water discharges into the area of Kissimmee Chain of Lakes are evident due to the fact that the surficial aquifer (SA) ground water elevations are consistently higher than the lake stages throughout the modeling period. Darcy's law is used to estimate the ground water contributions to the lakes (CDM 2008). Darcy's law is defined as:

$$(1) q = K \cdot dh/dl$$

Where:

q = specific discharge [L/T],

$K$  = hydraulic conductivity [L/T], and  
 $dh/dl$  = hydraulic gradient.

For a given lake, if the head difference ( $dh$ ) between the SA ground water elevation near the lake, the lake stage, lake bottom area ( $A$ ), lake bottom thickness ( $dl$ ), and its associated hydraulic conductivity ( $K$ ) are known, the ground water discharge  $Q$  [L<sup>3</sup>/T] to the lake can be estimated as follows:

$$(2) Q = A \cdot q = A \cdot K \cdot dh/dl$$

It should be emphasized that most of the lakes in the Project Area are directly connected to the SA, but not the Upper Floridan Aquifer (UFA); therefore, the SA ground water elevations were used in Darcy's law for the discharge estimations. Unlike the variation of the surface water elevations in natural rivers and lakes, the SA ground water elevations normally do not vary dramatically over a short period, such as a few days or weeks. However, the SA ground water elevations may vary seasonally by several feet. The variation of ground water elevations becomes more obvious from a wet season to a dry season and from a wet year to a dry year. To more accurately estimate ground water discharges to the lakes, monthly averages of the SA ground water elevations from the monitoring wells in the SA were obtained for the dry season of May and the wet season of September of each year from 1997 to 2006. A complete description of the techniques and information used to estimate the ground water contribution that was added to the baseflow estimation from HSPF can be found in Appendix 4C of the CDM 2008 report.

The comparison of measured and model-predicted stream flow values considered a number of factors that include: comparison of total flow volume for the entire simulation period and comparison of measured and modeled annual stream flow volume. The following methodologies were used to determine how well the simulated data compare to the measured data:

- Visual inspection of measured and modeled time series flow graphs: This method graphically compares the pattern of measured and modeled flows with respect to peak flows, hydrograph shapes, and comparison of high and low flow periods.
- Flow-Duration Curves: This method plots measured and modeled frequency-exceedance data to graphically indicate how the flows match for various frequencies of occurrence.
- Nash-Sutcliffe Score: This statistic is a measure of model efficiency, ranging from 0 to 1. A coefficient of zero indicates that model results for a parameter are no better than the average value of measured data for the modeled parameter over the period of simulation. A score of 1 indicates a perfect match between measured and modeled values. Mathematically, the Nash-Sutcliffe equation takes the ratio of the error variance to the variance in measured data, as follows:

$$E = 1 - [\sum (Q_m - Q_p)^2] / [\sum (Q_m - Q_{avg})^2]$$

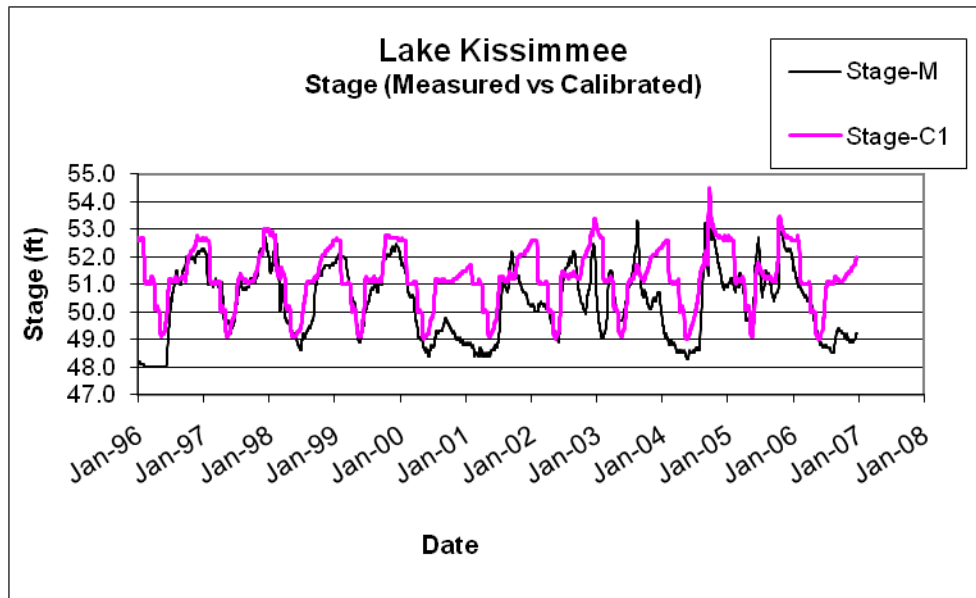
where:

- $E$  = coefficient of efficiency
- $Q_m$  = measured value
- $Q_p$  = modeled value
- $Q_{avg}$  = average measured value

- Tukey-Kramer comparison of means for the observed data vs. simulated results using the JMP version 8.0 software package.
- Stage Plots: Plots of modeled versus measured stages were developed for all the lakes with control structures and impaired WBIDs, where measured data are available.

Details of the hydrologic calibration/validation values and comparison of modeled and measured stream flows and lake stages for each planning unit are presented in Section 4 of the CDM, 2008 report. On average, inflows to the lake from Shingle Creek were within 7.7 percent of the measured flows at station SHING.ap with a Nash-Sutcliffe score of 0.38. A Nash-Sutcliffe score of 0.38 indicates that the model performed 38% better as a flow predictor, than using the mean of the observed data. Additionally, predictions of cumulative flow within 10% of the measured total flow are generally considered an acceptable calibration condition.

**Figure 5.7 Calibration and Validation Measured and Simulated Lake Stage**



As can be seen on **Figure 5.7**, (-M = measured, -C = calibration) the model over-predicted the stage during late 2000 through 2001 by about one to two feet. This discrepancy is thought to be due to irreconcilable differences between the written operating schedule controlling lake stage for the lake and the actual operation (CDM 2008). Another source of differences could be an underestimation of the lake contribution to ground water during dry periods, like 2000 (26.3 inches of rain). Even including these periods, the monthly mean model and measured stages depicted in **Figure 5.8** and summarized in **Table 5.4** for the calibration (1997 – 2001) and **Figure 5.9** and **Table 5.5** validation (2002 – 2006) periods were not significantly different at an alpha of 0.05. The difference in means for the 5-year calibration period was 0.24 feet and 0.35 feet for the 5-year validation period. During both periods, the simulated means were slightly greater than the measured means.

Figure 5.8 Calibration Results for Monthly Average Measured and Simulated Lake Stage

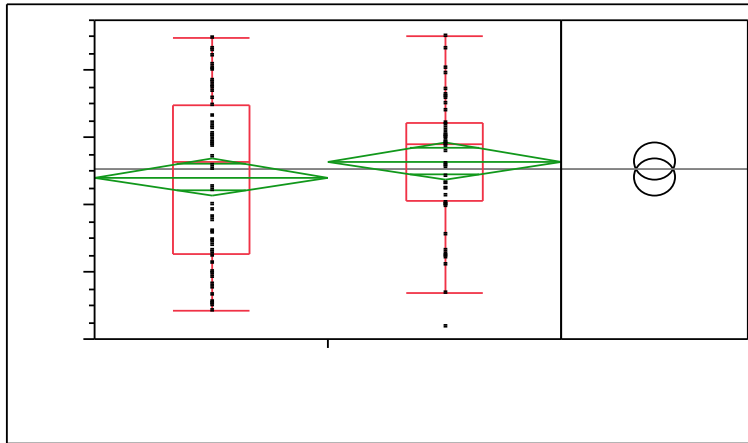
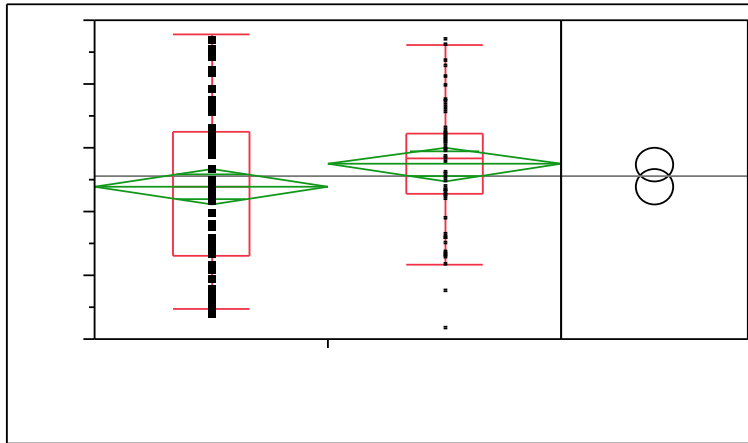


Table 5.4 Calibration Monthly Average Stage JMP Means Comparison

Means Comparisons		
Comparisons for all pairs using Tukey-Kramer HSD		
	q*	Alpha
	1.98027	0.05
Abs(Dif)-LSD	<b>Model-mC</b>	<b>Data-mC</b>
	-0.39499	-0.15821
	-0.15821	-0.39499
Positive values show pairs of means that are significantly different.		
<b>Level</b>		<b>Mean</b>
Model-mC	A	50.65
Data-mC	A	50.41
Levels not connected by same letter are significantly different.		

**Figure 5.9 Validation Results for Monthly Average Measured and Simulated Lake Stage**



**Table 5.5 Validation Monthly Average Stage JMP Means Comparison**

<b>Means Comparisons</b>		
<b>Comparisons for all pairs using Tukey-Kramer HSD</b>		
	<b>q*</b>	<b>Alpha</b>
	1.98027	0.05
Abs(Dif)-LSD	<b>Model-mV</b>	<b>Data-mV</b>
	-0.38374	-0.03464
	-0.03464	-0.38374

Positive values show pairs of means that are significantly different.

<b>Level</b>		<b>Mean</b>
Model-mV	A	50.74
Data-mV	A	50.39

Levels not connected by same letter are significantly different.

**Table 5.6 HSPF Simulated Annual Water Budget for Lake Kissimmee**

Year	Base flow	Inter flow	Runoff	GW Seepage (1)	Total Sub-basin	Total Up stream	Rainfall	Total Inflow	ET	Outflow	Change
	ac-ft	ac-ft	ac-ft	ac-ft	ac-ft	ac-ft	ac-ft	ac-ft	ac-ft	ac-ft	ac-ft
1996	14663	13721	1059	188579	218021	701042	140283	1059345	-162036	-896056	1253
1997	14348	12598	853	187519	215318	606485	150002	971806	-157912	-795821	18073
1998	21461	29431	1415	190030	242338	1018052	133578	1393967	-156499	-1263660	-26192
1999	21315	21953	1049	186188	230506	612772	151784	995062	-169472	-815560	10030
2000	5476	1919	316	190118	197829	314974	76380	589183	-174031	-485754	-70602
2001	9765	8686	618	187333	206402	526481	121192	854075	-167947	-628966	57162
2002	20623	19045	800	184195	224663	1034410	149193	1408266	-176300	-1202881	29085
2003	24919	22155	1559	190026	238659	1160523	145570	1544752	-166028	-1410684	-31960
2004	25627	43942	27986	195134	292690	1593278	183350	2069318	-179250	-1871255	18813
2005	42206	55871	21342	195354	314774	1526535	214639	2055948	-173426	-1884893	-2371
2006	9708	17521	1573	195683	224485	289630	96869	610983	-171111	-491440	-51567
AVG97-06	19545	23312	5751	190158	238766	868314	142256	1249336	-169198	-1085091	-4953
Percent	8.2	9.8	2.4	15.2	19.1	69.5	11.4	100	13.5	86.5	

(1) Estimated ground water contribution added to baseflow in model

**Table 5.6** depicts the model generated water budget for the lake. The average inflow from upstream basins (tributary inflow) is 868,314 acre-feet per year (ac-ft/yr), representing 69.5% of the total inflow to the lake. Surface runoff, interflow, baseflow, and ground water (added to baseflow as discussed above) generate 238,766 ac-ft/yr, or 19.1% of the total inflow. Direct rainfall on the lake (142,256 ac-ft/yr) makes up the remaining 11.4% of the total inflow of water to the lake.

Based on the model, the normal pool volume for the lake ranges between 216,000 and 368,000 ac-ft/yr. The annual average mean outflow is estimated as 1,085,091 ac-ft/yr. The mean residence time of a lake can be estimated as:

$$\text{Residence time (years)} = \text{lake volume (acre-ft)} / \text{mean outflow (acre-ft/yr)}$$

In this case, residence time is between two-tenths and thirty-four hundredths of a year, i.e., between 2 to 4 months (one month equals 0.083 of a year).

### Water Quality Calibration/Validation

**Table 5.7** presents input parameters that include assigned potency factors, interflow concentrations, and baseflow concentrations. For values showing ranges, the lower end of the ranges are applicable for undeveloped areas (e.g., forest, wetland), whereas the higher end of the ranges are applicable for agricultural areas.

**Table 5.7 Land-Based Water Quality Input Parameter Values**

HSPF Input Parameter	Water Quality Constituent						
	Ortho P	Ammonia N	Nitrate N	CBOD	Refractory Organic N	TP	TN
Interflow Concentration (mg/l)	0.03 - 0.22	0.03 - 0.08	0.20 - 0.63	1.5 - 19	0.7 - 1.2	0.04 - 0.39	1.0 - 2.8
Baseflow Concentration (mg/l)	0.02 - 0.04	0.02 - 0.05	0.13 - 0.25	1.5 - 3.0	0.6 - 0.8	0.03 - 0.07	0.8 - 1.2
Potency Factor (lb/ton sediment)	5.4 - 6.1	4.1	23 - 25	350	23.8	8.6 - 9.3	52 - 53

Based on values in **Table 5.7**, typical results for average annual constituent loads for various land use types and soil groups are presented in **Table 5.8**. The table shows a range of values, which reflect the differences associated with a variety of soil types (e.g., “A” soils generating less runoff than “D” soils). The values shown in the table are consistent with respect to loads estimated or measured in other studies.

**Table 5.8 Average Annual Land-Based Loading by Land Use Type and Soil Group**

	Soil Group	Average Annual Loads (lb/ac/yr)							
		Ortho P	Ammonia N	Nitrate N	CBOD	Refractory Organic N	TSS	Total P	Total N
Commercial / Industrial	A	1.03	0.7	4.3	60	4.4	330	1.58	11.9
	B	1.05	0.7	4.3	61	4.4	334	1.61	12.0
	C	1.07	0.8	4.4	62	4.5	338	1.63	12.2
	D	1.09	0.8	4.5	63	4.5	344	1.66	12.3
Cropland / Improved Pasture	A	0.18	0.1	0.8	14	2.4	1	0.30	3.9
	B	0.49	0.3	1.8	39	3.4	48	0.84	7.0
	C	0.75	0.4	2.7	58	4.4	111	1.28	9.9
	D	1.22	0.7	4.5	90	6.1	264	2.05	15.1
High Density Residential	A	0.69	0.5	3.0	41	3.6	206	1.07	8.8
	B	0.75	0.5	3.1	45	3.7	215	1.16	9.2
	C	0.80	0.6	3.3	48	3.8	226	1.24	9.7
	D	0.84	0.6	3.5	52	3.8	242	1.31	10.0
Low Density Residential	A	0.24	0.2	1.2	17	2.5	42	0.39	4.6
	B	0.35	0.3	1.5	26	2.7	57	0.58	5.5
	C	0.44	0.3	1.8	33	2.9	77	0.74	6.5
	D	0.53	0.4	2.1	41	3.0	104	0.90	7.2
Medium Density Residential	A	0.41	0.3	1.9	26	2.9	104	0.65	6.2
	B	0.50	0.4	2.1	34	3.1	116	0.80	6.9
	C	0.58	0.4	2.4	40	3.3	132	0.94	7.7
	D	0.65	0.5	2.6	46	3.3	156	1.07	8.3
Forest / Rangeland	A	0.05	0.0	0.3	4	1.4	0	0.08	1.9
	B	0.08	0.1	0.5	6	1.7	8	0.13	2.5
	C	0.12	0.1	0.7	8	1.9	20	0.19	3.1
	D	0.18	0.2	1.0	12	2.1	42	0.29	3.8
Unimproved Pasture	A	0.11	0.1	0.7	8	2.0	0	0.18	3.1
	B	0.20	0.2	1.0	16	2.2	18	0.34	4.0
	C	0.30	0.2	1.4	23	2.6	42	0.51	5.2
	D	0.43	0.3	2.0	32	2.9	87	0.72	6.5
Wetlands	A	---	---	---	---	---	---	---	---
	B	---	---	---	---	---	---	---	---
	C	---	---	---	---	---	---	---	---
	D	0.05	0.1	0.4	4	1.4	9	0.09	2.1

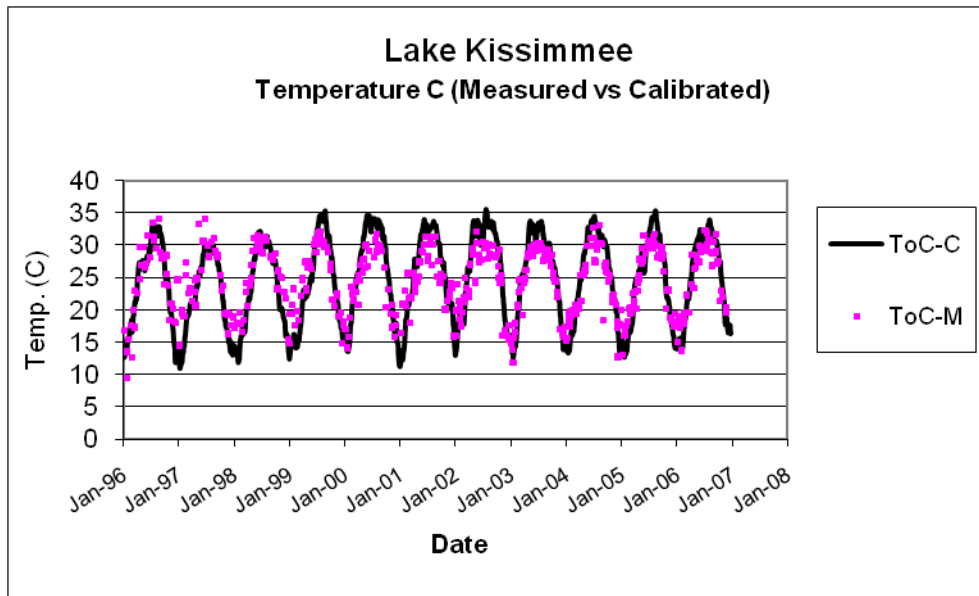
A discussion of the development of model input parameter values is presented below. The complete set of calibration values used in the modeling is listed in **Appendix C**.

Water temperature is not a cause of impairment, but it has an effect on water quality processes related to impairments. DO concentrations tend to be lower in the summer months when the water temperature is high, in part because the saturation DO for water decreases as temperature increases, and in part because processes that deplete DO (BOD decay, sediment oxygen demand) are also affected by water temperature. The modeling of water temperature in the reaches uses a number of meteorological time series (as discussed earlier), and a set of four input parameters.

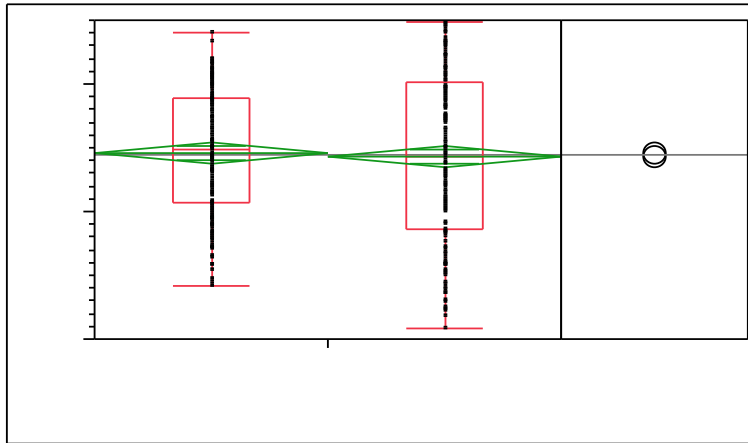
These parameters were all initially set at the default value, and one of the values was modified in the calibration process. Results showed that the water temperature simulations accurately captured the seasonal variability of the water temperature in the receiving waters. All of the calibration and validation results for all constituents presented below are based on a point-to-point comparison between the average of the measured data for a given day and the model predicted average for the same day. The calibration for annual average conditions is based on these daily averages of paired data from the model simulation and the measured data with the annual average based on the average of each calendar quarter.

As can be seen on **Figure 5.10**, (-M = measured, -C = calibration), the model predictions for temperature closely match the measured data, accurately capturing the annual and seasonal variability of the water temperature. The daily model and measured temperatures depicted in **Figure 5.11** and summarized in **Table 5.9** for the calibration (1997 – 2001) and **Figure 5.12** and **Table 5.10** validation (2002 – 2006) periods were not significantly different at an alpha of 0.05 and calibration proceeded for other water quality variables.

**Figure 5.10 Measured and Simulated Lake Temperature**



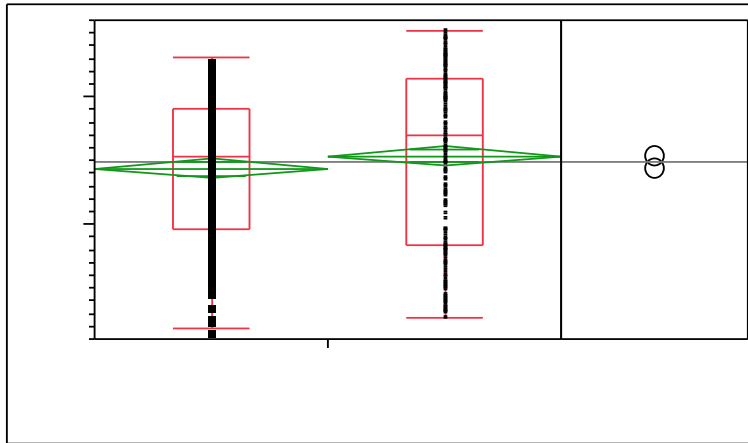
**Figure 5.11 Calibration Results for Daily Measured and Simulated Lake Temperature**



**Table 5.9 Calibration Daily Temperature JMP Means Comparison**

<b>Means Comparisons</b>		
<b>Comparisons for all pairs using Tukey-Kramer HSD</b>		
	<b>q*</b>	<b>Alpha</b>
	1.96588	0.05
Abs(Dif)-LSD		
Data-C	<b>Data-C</b>	<b>Model-C</b>
	-1.13418	-0.79728
	-0.79728	-1.13418
Positive values show pairs of means that are significantly different.		
	<b>Level</b>	<b>Mean</b>
	Data-C A	24.61
	Model-C A	24.27
Levels not connected by same letter are significantly different.		

**Figure 5.12 Validation Results for Daily Measured and Simulated Lake Temperature**



**Table 5.10 Validation Daily Temperature JMP Means Comparison**

Means Comparisons		
Comparisons for all pairs using Tukey-Kramer HSD		
	q*	Alpha
	1.96466	0.05
Abs(Dif)-LSD		
Model-V	-1.06304	-0.05068
Data-V	-0.05068	-1.06304
Positive values show pairs of means that are significantly different.		
Level		Mean
Model-V	A	25.36
Data-V	A	24.35
Levels not connected by same letter are significantly different.		

As discussed in Chapter 4, in the evaluation of nutrients and phytoplanktonic algae (as chlorophyll *a*), the HSPF model accounts for the following water quality constituents:

- Organic nitrogen (organic N);
- Ammonia nitrogen (ammonia N);
- Nitrite + nitrate nitrogen (nitrate N);
- Organic phosphorus (organic P);
- Inorganic phosphorus (inorganic P); and

- Phytoplanktonic algae (chlorophyll a).

Organic N and organic P in the model are associated with several water quality constituents, which include ultimate CBOD, phytoplankton, and refractory organics that are the result of the death of algae.

The key processes that affect the model simulation of phytoplankton concentration in receiving waters include the following:

- Phytoplankton growth;
- Phytoplankton respiration;
- Phytoplankton death; and
- Phytoplankton settling.

Phytoplankton growth is modeled based on a specified maximum growth rate, which is adjusted by the model based on water temperature, and is limited by the model based on available light and inorganic N and P. Similarly, death and respiration are modeled based on specified rates that are adjusted for water temperature. A higher death rate may be applied by the model under certain conditions (*e.g.*, high water temperature, high chlorophyll a concentration). Settling is modeled based on a constant settling rate. Growth increases the concentration of phytoplankton, whereas the other processes reduce the concentration of phytoplankton.

The key processes that affect the model simulation of nitrogen concentrations in receiving waters include the following:

- First-order decay of BOD (organic N associated with BOD is converted to ammonia N in this process);
- BOD settling (organic N associated with BOD is lost to the lake sediments);
- Phytoplankton growth (inorganic N is converted to phytoplankton N);
- Phytoplankton respiration (phytoplankton N is converted to ammonia N);
- Phytoplankton death (phytoplankton N is converted to BOD and/or refractory organic N);
- Phytoplankton settling (phytoplankton N is lost to the lake sediments);
- Refractory organic N settling to lake sediments;
- Nitrification (conversion of ammonia N to nitrate N); and
- Sediment flux (ammonia N is released from sediment to overlying water).

Ultimately, the rate at which nitrogen is removed from the receiving water depends on the rate at which inorganic N is converted to organic N (by phytoplankton growth) and the rate at which the organic N forms (as BOD, as refractory organic N, and as phytoplankton N) settle to the lake sediments.

The key processes that affect the model simulation of phosphorus concentrations in the lake include the following:

- First-order decay of BOD (organic P associated with BOD is converted to inorganic P in this process);
- BOD settling (organic P associated with BOD is lost to the lake sediments);
- Phytoplankton growth (inorganic P is converted to phytoplankton P);
- Phytoplankton respiration (phytoplankton P is converted to inorganic P);
- Phytoplankton death (phytoplankton P is converted to BOD and/or refractory organic P);
- Phytoplankton settling (phytoplankton P is lost to the lake sediments);
- Refractory organic P settling to lake sediments; and
- Sediment flux (inorganic P is released from sediment to overlying water).

Ultimately, the rate at which phosphorus is removed from the lake water depends on the rate at which inorganic P is converted to organic P (by phytoplankton growth) and the rate at which the organic P forms (as BOD, as refractory organic P, and as phytoplankton P) settle to the lake sediments.

Lake Kissimmee has an extended watershed including other lakes and streams. Waterbodies with long mean residence times (months or years), allow substantial time and relatively quiescent conditions for phytoplankton growth. In contrast, these processes are expected to have little impact in free-flowing stream reaches with short residence times (a day or less) and relatively turbulent conditions. However, it is possible to see high phytoplankton levels in streams during dry weather periods, if the stream has some areas of standing water.

For DO, the key processes affecting concentrations in the reaches include the following:

- Reaeration;
- Phytoplankton growth and respiration;
- BOD decay;
- Nitrification; and
- Sediment oxygen demand (SOD).

Reaeration is a process of exchange between the water and the overlying atmosphere, which typically brings oxygen into the receiving water (unless the receiving water DO concentration is above saturation levels). In the long-term, phytoplankton growth and respiration typically provides a net DO benefit (*i.e.*, introduces more DO through growth than is depleted through respiration). The other three processes take oxygen from the receiving water. Results of the modeling suggest that reaeration and SOD are often the key processes in the overall DO mass balance, though the other processes may be important in lakes that have relatively high loadings.

The model simulates flows and associated loads from the tributary area into the Lake Kissimmee (RCHRES 480) to perform HSPF water quality calculations. Simulations included concentrations of water quality constituents including phytoplankton, and various forms of nitrogen and phosphorus. During HSPF calibration, water quality input parameters that represent the physical and biological processes in the lake were set so that the simulated concentrations were comparable to the available measured water quality data for Lake Kissimmee.

The daily TN calibration/validation results are depicted in **Figure 5.13** (-M = measured, -C = calibration). This figure indicates that the model is reasonably predicting the seasonal and annual variations in the measured data. The results for the TN calibration/validation for annual average conditions are depicted in **Figure 5.14**. This figure indicates that the model is reasonably predicting the annual variations in the measured data. **Figure 5.15** and **Table 5.11** comparing TN model annual average calibration predictions to the measured data indicate the means are not significantly different at an alpha of 0.05. The annual average TN validation results (**Figure 5.16** and **Table 5.12**) comparing model predictions to the measured data indicate the means are not significantly different at an alpha of 0.05. The model mean was slightly (0.01 mg/L) over the measured mean for the calibration period and the validation period (0.03 mg/L). Additionally, as the TMDL will be based on the annual average (overall model period 1997 – 2006) response of the lake to nutrient load reductions, a comparison of means for this period was conducted. **Figure 5.17** and **Table 5.13** present the results for this comparison. While the model is over predicting TN by 0.03 mg/L, the means were not significantly different at an alpha of 0.05. Based on these results, the model is considered suitable for predicting the lake response to changes in total nitrogen loadings.

**Figure 5.13 Total Nitrogen Daily Measured Data and Simulated Results (1996 - 2006)**

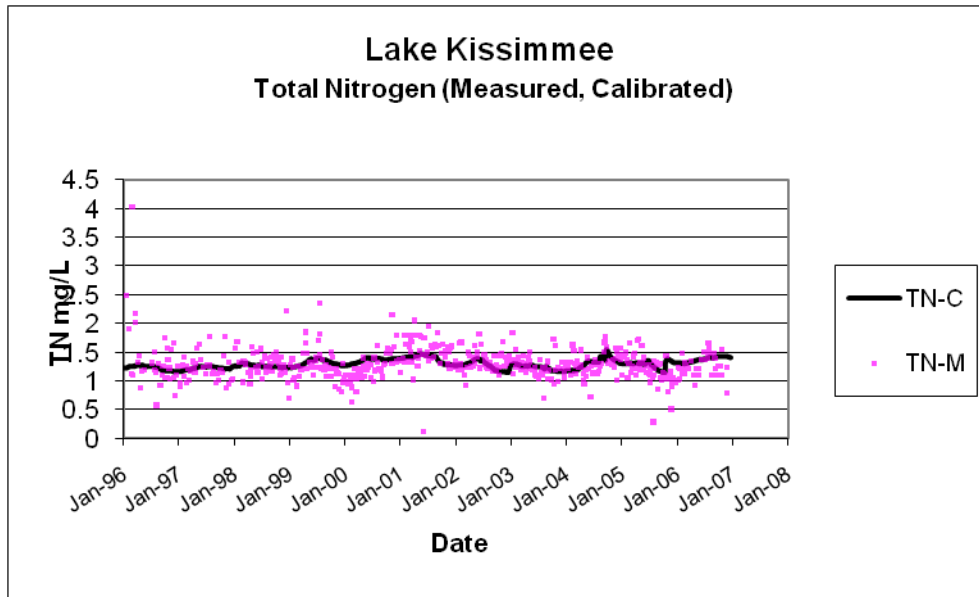
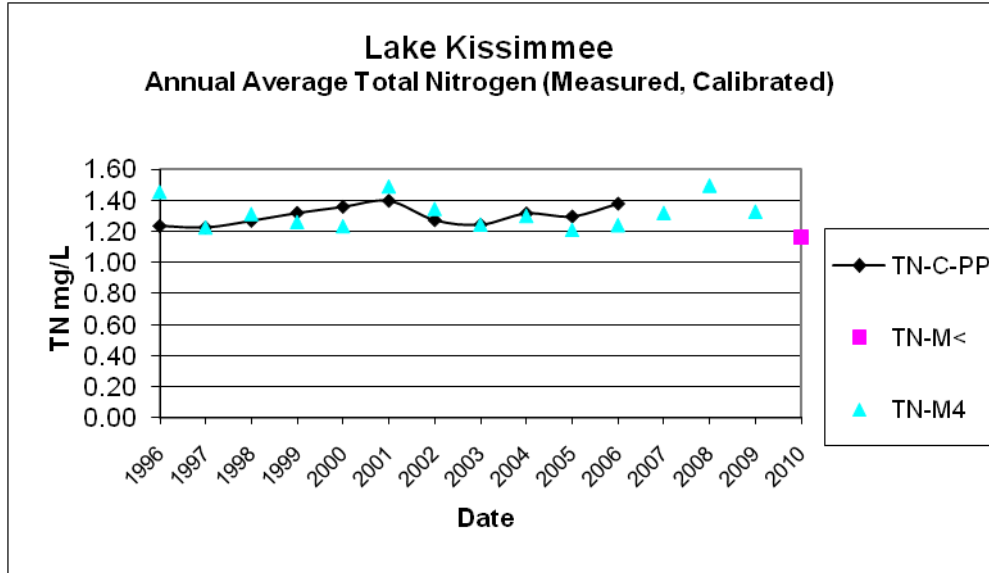
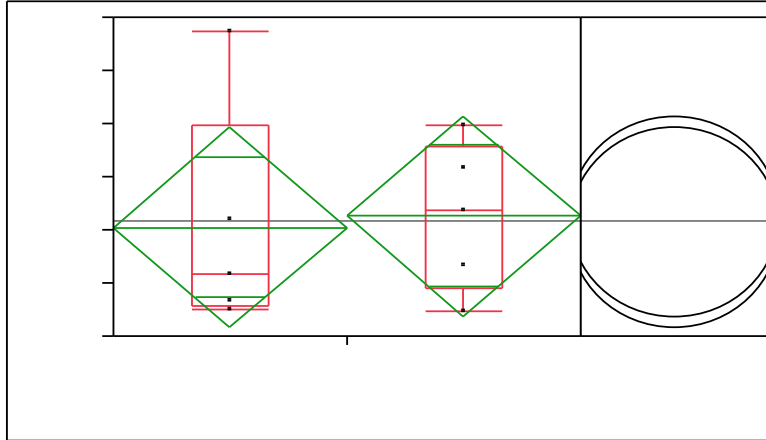


Figure 5.14 Total Nitrogen Annual Average Measured Data (1996 – 2009) and Simulated Results (1996 - 2006)



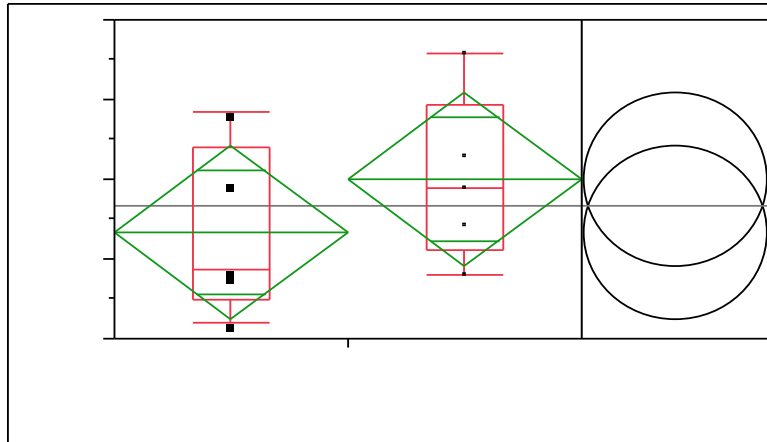
**Figure 5.15 Total Nitrogen (mg/L) Annual Average Calibration**



**Table 5.11 Total Nitrogen Annual Average Calibration JMP Means Comparison**

<b>Means Comparisons</b>		
<b>Comparisons for all pairs using Tukey-Kramer HSD</b>		
	<b>q*</b>	<b>Alpha</b>
	2.30598	0.05
Abs(Dif)-LSD	<b>Model-C</b>	<b>Data-C</b>
	-0.13276	-0.12226
	-0.12226	-0.13276
Positive values show pairs of means that are significantly different.		
	<b>Level</b>	<b>Mean</b>
	Model-C A	1.31
	Data-C A	1.30
Levels not connected by same letter are significantly different.		

**Figure 5.16 Total Nitrogen (mg/L) Annual Average Validation**



**Table 5.12 Total Nitrogen Annual Average Validation JMP Means Comparison**

<b>Means Comparisons</b>		
<b>Comparisons for all pairs using Tukey-Kramer HSD</b>		
	<b>q*</b>	<b>Alpha</b>
	2.30598	0.05
Abs(Dif)-LSD	<b>Model-V</b>	<b>Data-V</b>
	-0.07681	-0.04351
	-0.04351	-0.07681

Positive values show pairs of means that are significantly different.

<b>Level</b>	<b>Mean</b>
Model-V A	1.30
Data-V A	1.27

Levels not connected by same letter are significantly different.

Figure 5.17 Total Nitrogen (mg/L) Annual Average 1997 - 2006

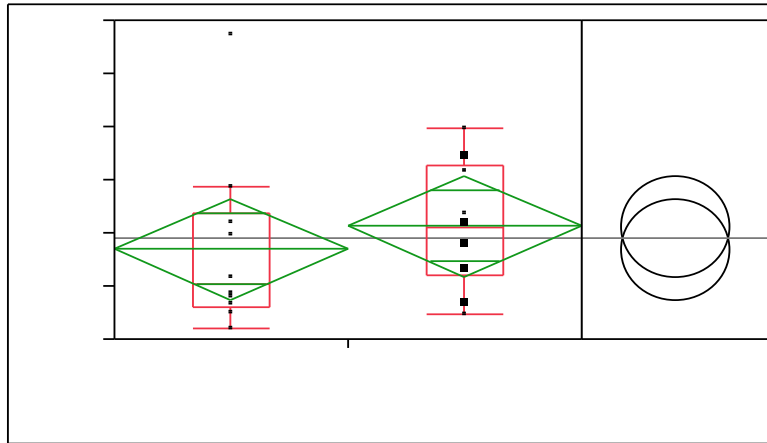


Table 5.13 Total Nitrogen Annual Average JMP Means Comparison 1997 - 2006

Means Comparisons		
Comparisons for all pairs using Tukey-Kramer HSD		
	q*	Alpha
Abs(Dif)-LSD	2.10092	0.05
Model-All	-0.06721	-0.04531
Data-All	-0.04531	-0.06721

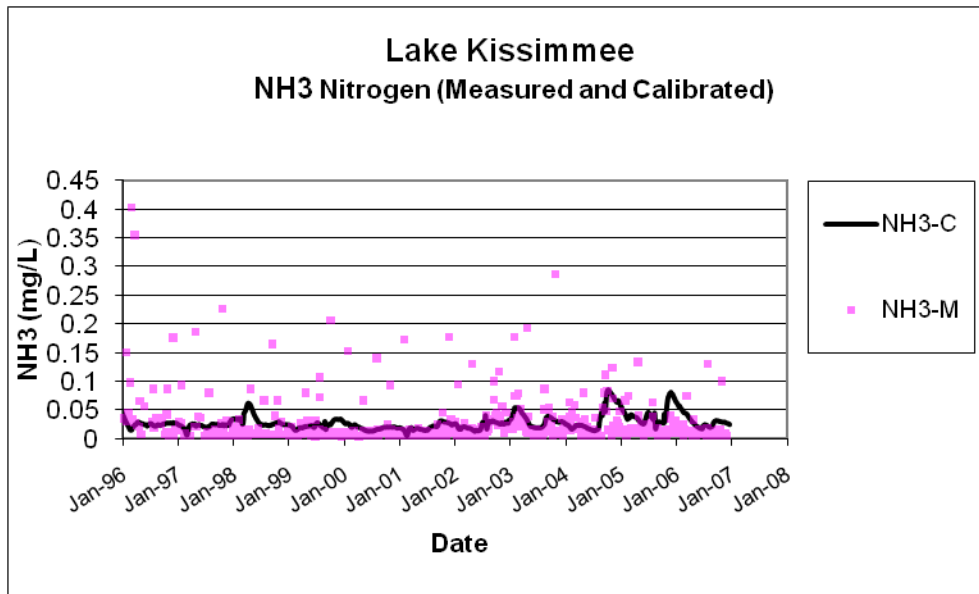
Positive values show pairs of means that are significantly different.

Level	Mean
Model-All	1.31
Data-All	1.28

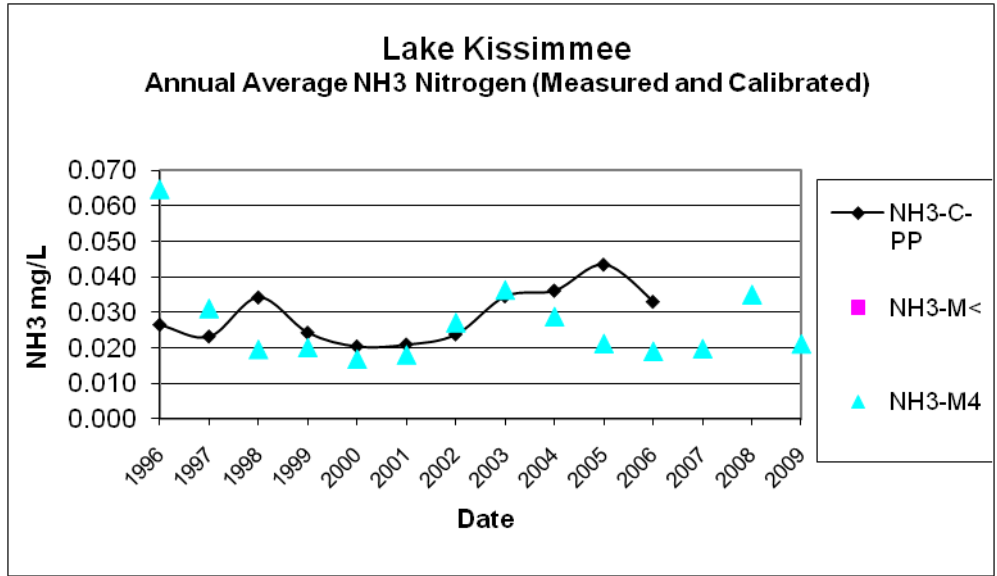
Levels not connected by same letter are significantly different.

The daily NH<sub>3</sub>-N calibration/validation results are depicted in **Figure 5.18**. Although the model is not matching the periodic high NH<sub>3</sub>-N concentrations measured in the lake (by multiple data providers), the figure indicates that the model is reasonably predicting the seasonal and annual variations in the measured data. The results for the NH<sub>3</sub>-N calibration/validation for annual average conditions are depicted in **Figure 5.19**. This figure indicates that the model is reasonably predicting the pattern in the annual variations of the measured data. **Figure 5.20** and **Table 5.14** comparing model annual average calibration predictions to the measured data, indicate the means are not significantly different at an alpha of 0.05. The annual average NH<sub>3</sub>-N validation results (**Figure 5.21** and **Table 5.15**) comparing model predictions to the measured data, indicate the means are not significantly different at an alpha of 0.05. The model mean was slightly (0.003 mg/L) over the measured mean for the calibration period and the validation period (0.007 mg/L). Additionally, as the TMDL will be based on the annual average (overall model period 1997 – 2006) response of the lake to nutrient load reductions, a comparison of means for this period was conducted. **Figure 5.22** and **Table 5.16** present the results for this comparison. While the model is over predicting NH<sub>3</sub>-N by 0.005 mg/L, the means were not significantly different at an alpha of 0.05. Based on these results, the model is considered suitable for predicting the lake response to changes in total ammonia loadings.

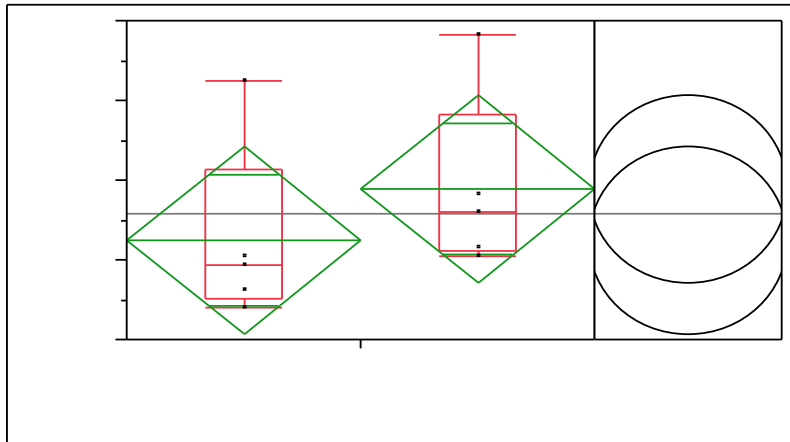
**Figure 5.18 Total Ammonia Daily Measured Data and Simulated Results (1996 - 2006)**



**Figure 5.19 Total Nitrogen Ammonia Annual Average Measured Data (1996 – 2009) and Simulated Results (1996 - 2006)**



**Figure 5.20 Total Ammonia (mg/L) Annual Average Calibration**



**Table 5.14 Total Ammonia Annual Average Calibration JMP Means Comparison**

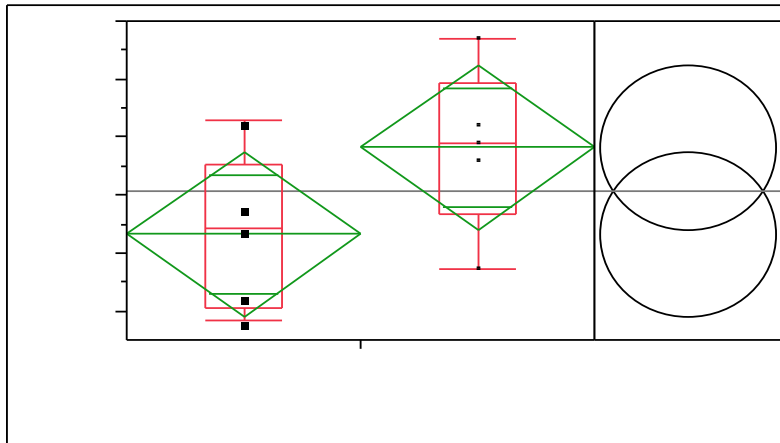
<b>Means Comparisons</b>		
<b>Comparisons for all pairs using Tukey-Kramer HSD</b>		
	<b>q*</b>	<b>Alpha</b>
	2.30598	0.05
Abs(Dif)-LSD	<b>Model-C</b>	<b>Data-C</b>
	-0.00827	-0.00504
	-0.00504	-0.00827

Positive values show pairs of means that are significantly different.

<b>Level</b>		<b>Mean</b>
Model-C	A	0.024
Data-C	A	0.021

Levels not connected by same letter are significantly different.

**Figure 5.21 Total Ammonia (mg/L) Annual Average Validation**



**Table 5.15 Total Ammonia Annual Average Validation JMP Means Comparison**

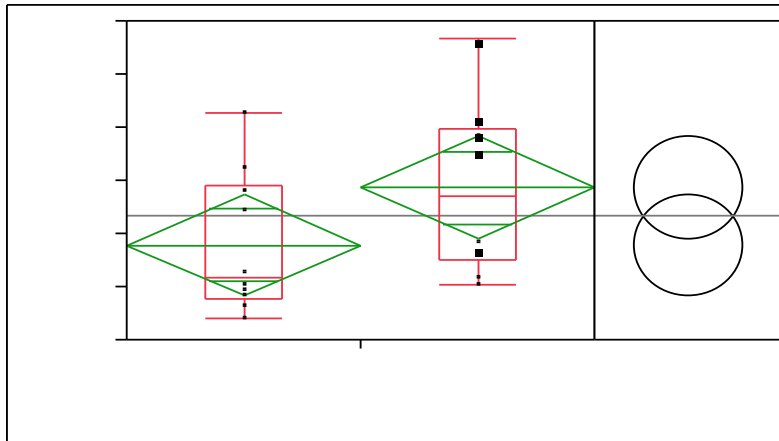
<b>Means Comparisons</b>		
<b>Comparisons for all pairs using Tukey-Kramer HSD</b>		
	<b>q*</b>	<b>Alpha</b>
	2.30598	0.05
Abs(Dif)-LSD		
Model-V	-0.01013	-0.00263
Data-V	-0.00263	-0.01013

Positive values show pairs of means that are significantly different.

<b>Level</b>		<b>Mean</b>
Model-V	A	0.034
Data-V	A	0.027

Levels not connected by same letter are significantly different.

**Figure 5.22 Total Ammonia (mg/L) Annual Average 1997 - 2006**



**Table 5.16 Total Ammonia Annual Average JMP Means Comparison 1997 - 2006**

Means Comparisons		
Comparisons for all pairs using Tukey-Kramer HSD		
	q*	Alpha
	2.10092	0.05
Abs(Dif)-LSD		
Model-All	-0.00682	-0.00145
Data-All	-0.00145	-0.00682

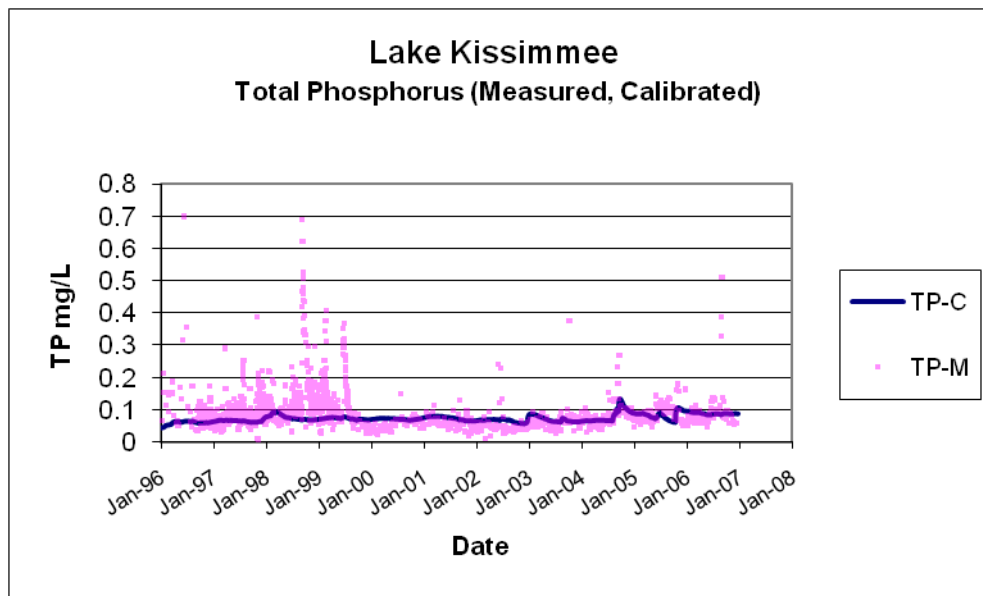
Positive values show pairs of means that are significantly different.

Level		Mean
Model-All	A	0.029
Data-All	A	0.024

Levels not connected by same letter are significantly different.

During the initial calibration for TP, the model was under predicting both TP and ortho-phosphate-P (PO<sub>4</sub>-P) to such a degree, that TP would not calibrate without initiating a benthic flux of PO<sub>4</sub>-P from the bed of the lake. The pattern and magnitude of the TP displayed in **Figure 5.23** and PO<sub>4</sub>-P in **Figure 5.28** is supportive of this decision. The daily TP calibration/validation results are depicted in **Figure 5.23** and indicate that the model is reasonably predicting the seasonal and annual variations in the measured data.

**Figure 5.23 Total Phosphorus Daily Measured Data and Simulated Results (1996 - 2006)**



The results for the TP calibration/validation for annual average conditions are depicted in **Figure 5.24**. This figure indicates that the model is under predicting the TP during the calibration period due to periodic high values in the measured data as seen on **Figure 5.23**. The model does an excellent job of predicting the annual variations in TP during the validation period. **Figure 5.25** and **Table 5.17** comparing model annual average calibration predictions to the measured data, indicate that while the model is under predicting the TP by 0.018 mg/L, the means are not significantly different at an alpha of 0.05. The annual average TP validation results (**Figure 5.26** and **Table 5.18**) comparing model predictions to the measured data, indicate the means are not significantly different at an alpha of 0.05. The model mean was within 0.0003 mg/L of the measured mean for the validation period. Additionally, as the TMDL will be based on the annual average (overall model period 1997 – 2006) response of the lake to nutrient load reductions, a comparison of means for this period was conducted. **Figure 5.27** and **Table 5.19** present the results for this comparison. While the model is under-predicting TP by 0.009 mg/L, the means were not significantly different at an alpha of 0.05. Based on these results, the model is considered suitable for predicting the lake response to changes in TP loadings.

**Figure 5.24 Total Phosphorus Annual Average Measured Data (1996 – 2009) and Simulated Results (1996 - 2006)**

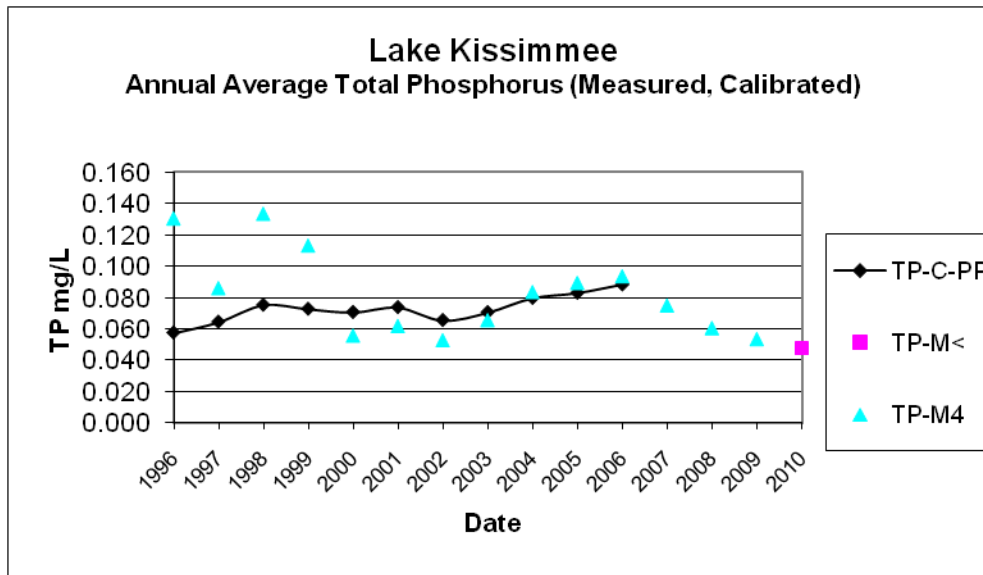


Figure 5.25 Total Phosphorus (mg/L) Annual Average Calibration

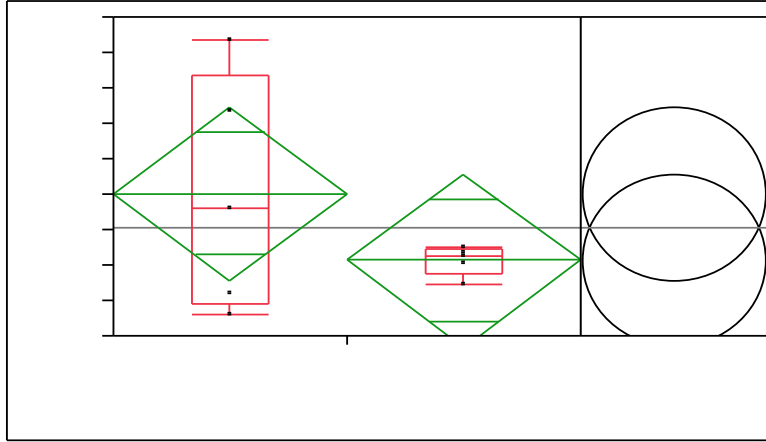
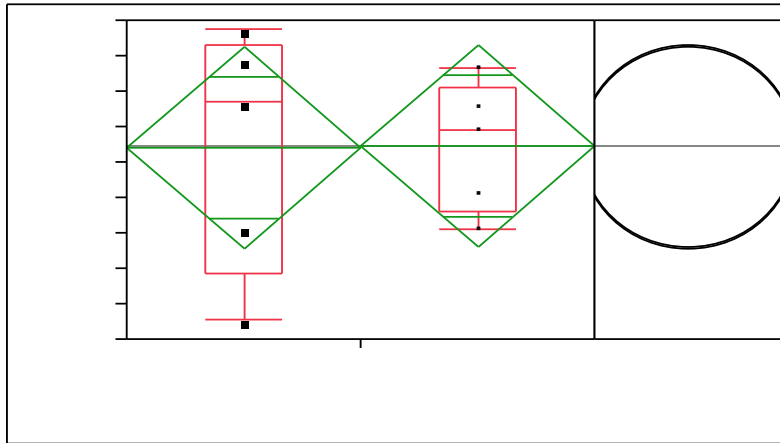


Table 5.17 Total Phosphorus Annual Average Calibration JMP Means Comparison

Means Comparisons		
Comparisons for all pairs using Tukey-Kramer HSD		
	q*	Alpha
	2.30598	0.05
Abs(Dif)-LSD	<b>Data-C</b>	<b>Model-C</b>
Data-C	-0.03452	-0.01565
Model-C	-0.01565	-0.03452
Positive values show pairs of means that are significantly different.		
<b>Level</b>	<b>Mean</b>	
Data-C	A	0.0901
Model-C	A	0.0712
Levels not connected by same letter are significantly different.		

**Figure 5.26 Total Phosphorus (mg/L) Annual Average Validation**



**Table 5.18 Total Phosphorus Annual Average Validation JMP Means Comparison**

<b>Means Comparisons</b>		
<b>Comparisons for all pairs using Tukey-Kramer HSD</b>		
	<b>q*</b>	<b>Alpha</b>
	2.30598	0.05
<b>Abs(Dif)-LSD</b>		
Model-V	-0.02014	-0.0199
Data-V	-0.0199	-0.02014
Positive values show pairs of means that are significantly different.		
<b>Level</b>		<b>Mean</b>
Model-V	A	0.0773
Data-V	A	0.0770
Levels not connected by same letter are significantly different.		

Figure 5.27 Total Phosphorus (mg/L) Annual Average 1997 - 2006

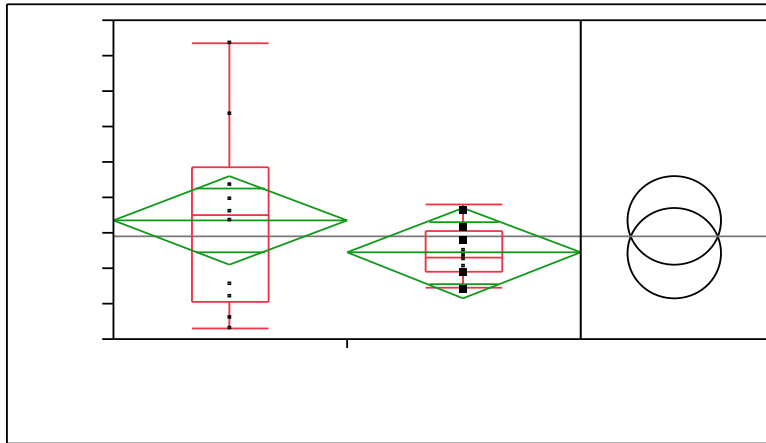
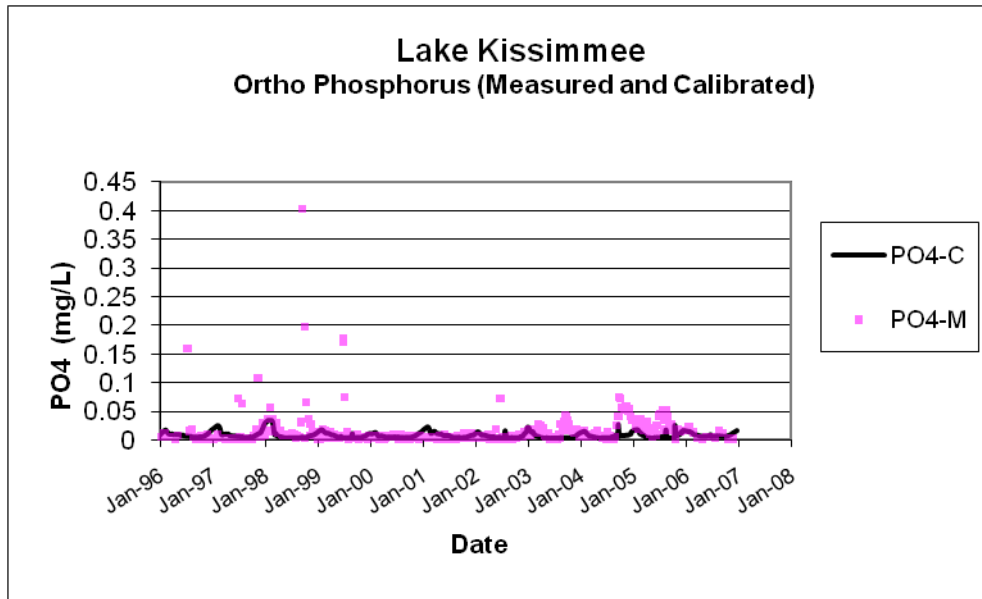


Table 5.19 Total Phosphorus Annual Average JMP Means Comparison 1997 – 2006

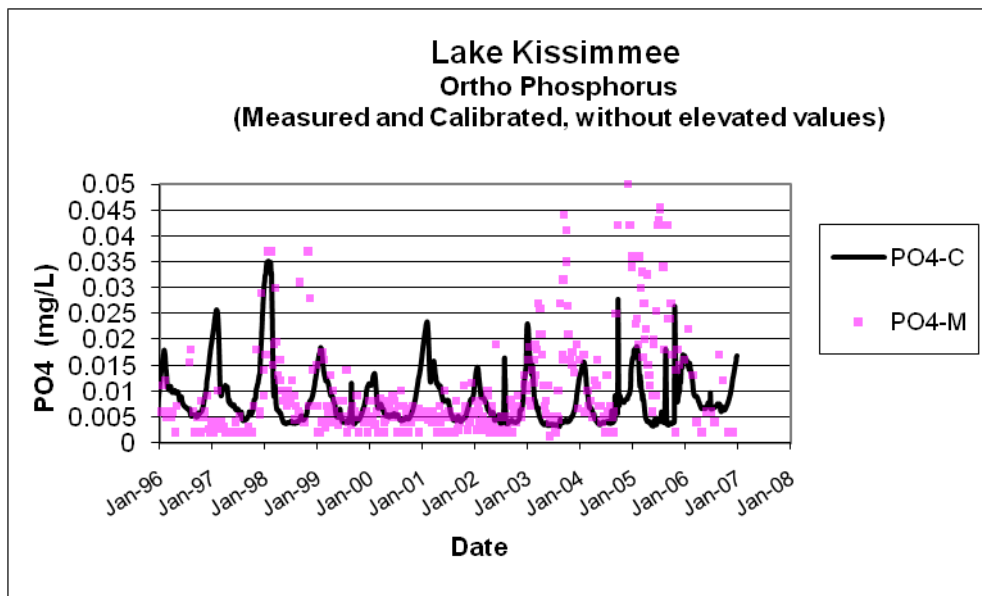
Means Comparisons		
Comparisons for all pairs using Tukey-Kramer HSD		
	q*	Alpha
	2.10092	0.05
Abs(Dif)-LSD	<b>Data-All</b>	<b>Model-All</b>
	-0.01789	-0.00858
	-0.00858	-0.01789
Positive values show pairs of means that are significantly different.		
Level		Mean
Data-All	A	0.0836
Model-All	A	0.0743
Levels not connected by same letter are significantly different.		

During the initial calibration, the model was under-predicting both TP and PO<sub>4</sub>-P to such a degree that neither constituent would calibrate without initiating a benthic flux of PO<sub>4</sub>-P from the bed of the lake. The pattern and magnitude of the PO<sub>4</sub>-P measured data displayed in **Figure 5.28a** is supportive of this decision. The daily PO<sub>4</sub>-P calibration/validation results (without periodic high values) are depicted in **Figure 5.28b**. This figure shows that with the addition of a benthic flux, the model is reasonably matching both the seasonal and annual pattern of PO<sub>4</sub>-P.

**Figure 5.28a Ortho-phosphate Daily Measured Data and Simulated Results (1996 2006)**

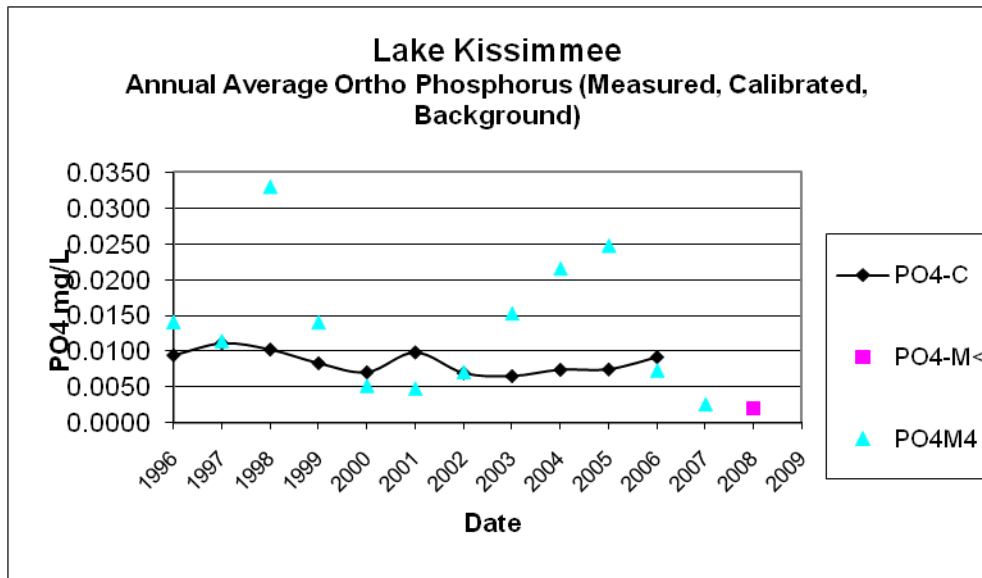


**Figure 5.28b Ortho-phosphate Daily Measured Data and Simulated Results (1996 2006) without elevated values**

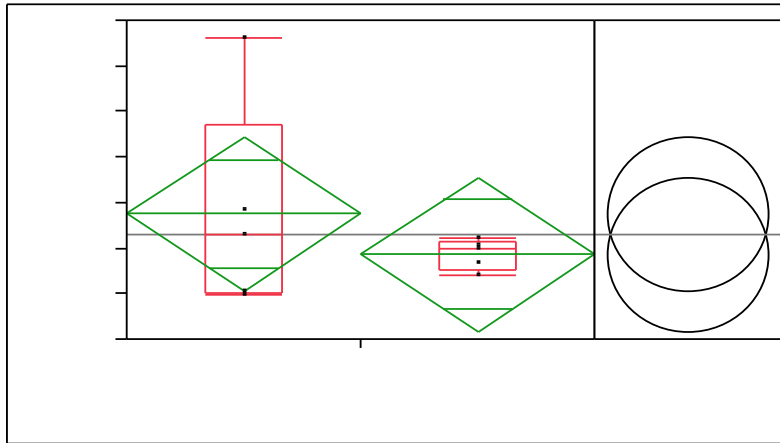


The results for the PO<sub>4</sub>-P calibration/validation for annual average conditions are depicted in **Figure 5.29**. Even with the introduction of benthic flux, making up 15.5% of the TP mass budget, the model is under-predicting the PO<sub>4</sub>-P and would require a significant increase in the benthic flux of PO<sub>4</sub>-P to close the gap. The rate of benthic flux was fixed at the minimum level required to calibrate/validate the model TP and PO<sub>4</sub>-P predictions. **Figure 5.30** and **Table 5.20**, comparing model annual average calibration predictions to the measured data, indicate the means are not significantly different at an alpha of 0.05. The annual average validation results (**Figure 5.31** and **Table 5.21**) comparing model predictions to the measured data, indicate the means are not significantly different at an alpha of 0.05. The model mean was 0.0044 mg/L under the measured mean for the calibration period and 0.0077 mg/L for the validation period. Additionally, as the TMDL will be based on the annual average (overall model period 1997 – 2006) response of the lake to nutrient load reductions, a comparison of means for this period was conducted. **Figure 5.32** and **Table 5.22** present the results for this comparison. While the model is under predicting PO<sub>4</sub>-P by 0.0061 mg/L, the means were not significantly different at an alpha of 0.05. Based on these results, the model is considered suitable for predicting the lake response to changes in PO<sub>4</sub>-P loadings.

**Figure 5.29 Ortho-phosphate Annual Average Measured Data (1996 – 2009) and Simulated Results (1996 - 2006)**



**Figure 5.30 Ortho-phosphate (mg/L) Annual Average Calibration**



**Table 5.20 Ortho-phosphate Annual Average Calibration JMP Means Comparison**

<b>Means Comparisons</b>		
<b>Comparisons for all pairs using Tukey-Kramer HSD</b>		
	<b>q*</b>	<b>Alpha</b>
	2.30598	0.05
<b>Abs(Dif)-LSD</b>		
Data-C	-0.01196	-0.00753
Model-C	-0.00753	-0.01196
Positive values show pairs of means that are significantly different.		
	<b>Level</b>	<b>Mean</b>
Data-C	A	0.0137
Model-C	A	0.0093
Levels not connected by same letter are significantly different.		

Figure 5.31 Ortho-phosphate (mg/L) Annual Average Validation

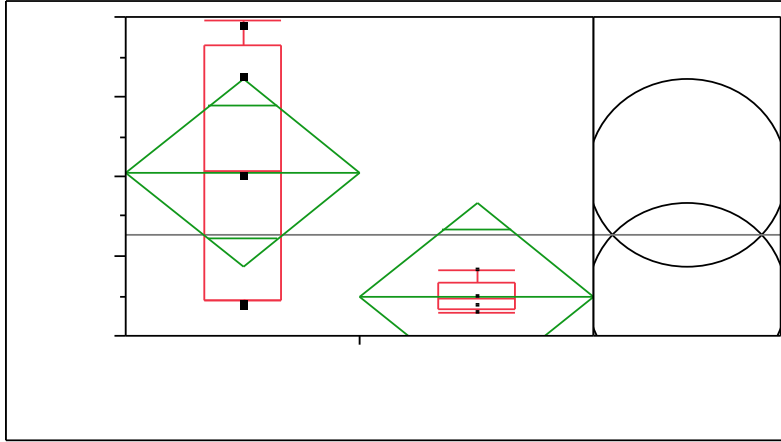


Table 5.21 Ortho-phosphate Annual Average Validation JMP Means Comparison

Means Comparisons		
Comparisons for all pairs using Tukey-Kramer HSD		
	$q^*$	Alpha
	2.30598	0.05
Abs(Dif)-LSD	<b>Data-V</b>	<b>Model-V</b>
	Data-V	-0.00836
	Model-V	-0.00836
Positive values show pairs of means that are significantly different.		
	<b>Level</b>	<b>Mean</b>
	Data-V	A
	Model-V	A
Levels not connected by same letter are significantly different.		

Figure 5.32 Ortho-phosphate (mg/L) Annual Average 1997 - 2006

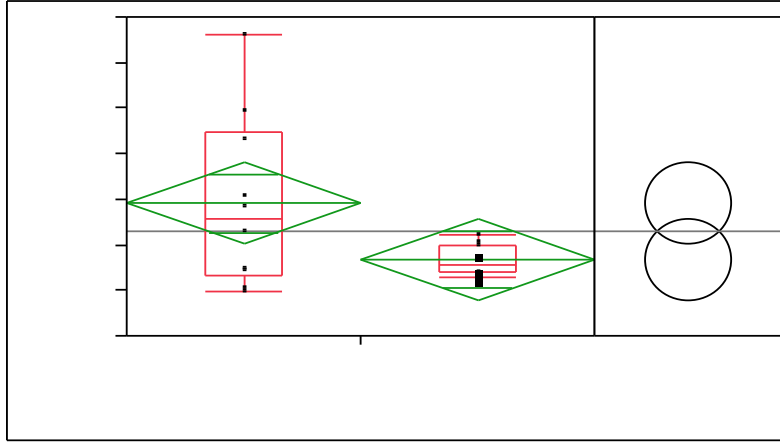


Table 5.22 Ortho-phosphate Annual Average JMP Means Comparison 1997 - 2006

Means Comparisons		
Comparisons for all pairs using Tukey-Kramer HSD		
Abs(Dif)-LSD	$q^*$	Alpha
	2.10092	0.05
	<b>Data-All</b>	<b>Model-All</b>
Data-All	-0.00632	-0.00021
Model-All	-0.00021	-0.00632

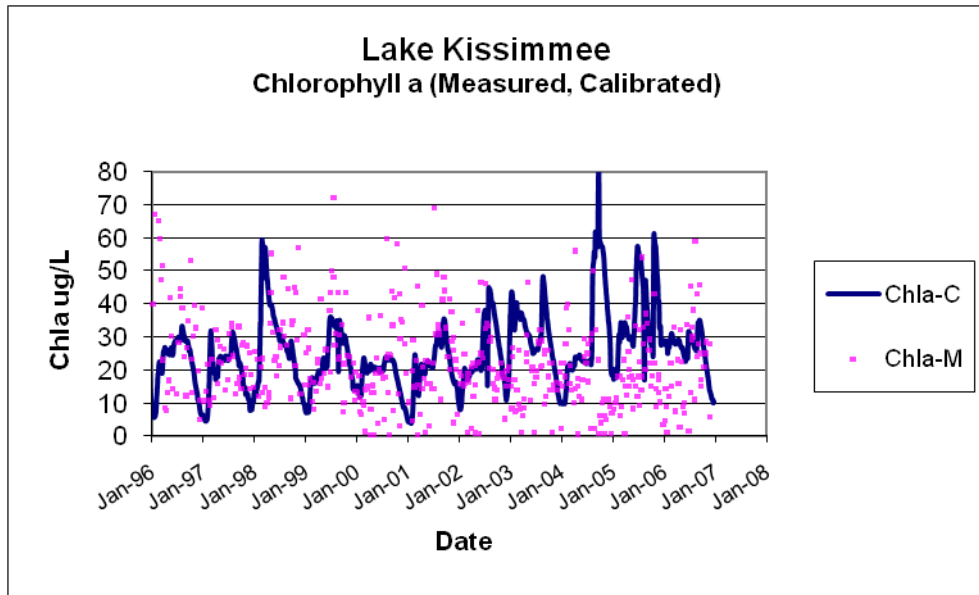
Positive values show pairs of means that are significantly different.

Level		Mean
Data-All	A	0.0145
Model-All	A	0.0084

Levels not connected by same letter are significantly different.

The daily corrected chlorophyll a (CChla) calibration/validation results are depicted in **Figure 5.33**. These results indicate that the model is reasonably matching both the seasonal and annual variations in CChla and the periodic high and low concentrations measured in the lake (by multiple data providers).

**Figure 5.33 Corrected Chlorophyll a Daily Measured Data and Simulated Results (1996 - 2006)**



The results for the CChla calibration/validation for annual average conditions are depicted in **Figure 5.34**. This figure indicates that the model is reasonably predicting the pattern and magnitude in the annual variations of the measured data during the calibration period and significantly over predicting the CChla during the validation period. **Figure 5.35** and **Table 5.23** comparing model annual average calibration predictions to the measured data, indicate the means are not significantly different at an alpha of 0.05. The annual average validation results (**Figure 5.36** and **Table 5.24**) comparing model predictions to the measured data, indicate the means are significantly different at an alpha of 0.05. The model mean was 2.0 ug/L under the measured mean for the calibration period and 10.5 ug/L over during the validation period. The model was calibrated to a period when the median lake color was only 48 PCU. The median color during the validation period was 103 PCU, over twice as high with values up to 350 PCU. It is possible that the high color present during the validation period inhibited the production of algal biomass in the lake. Given that (1) the measured median ammonia, nitrate, and ortho-p concentrations were higher during the validation period, while the median CChla was lower, (2) that the annual average variations in CChla during the validation period generally track the variations in color (color up, CChla down), and (3) the model predictions in CChla follow the trends in the PO4-P data (increasing concentrations of PO4-P produced higher CChla predictions, all support this possibility. If this was the case, calibrating the model to a lower color condition would result in over production of algal biomass during periods where color could be inhibiting CChla production and nutrients were present in abundance. Additionally, as the TMDL will be based on the annual average (overall model period 1997 – 2006) response of the lake to nutrient load reductions, a comparison of means for this period was conducted. **Figure 5.37** and **Table 5.25** present the results for this comparison. The 10-year means were not significantly different at an alpha of 0.05. Based on these results, the model is considered suitable for predicting the average lake CChla response to changes in nutrient loadings over the 10-year period.

**Figure 5.34 Corrected Chlorophyll a Annual Average Measured Data (1996 – 2009) and Simulated Results (1996 - 2006)**

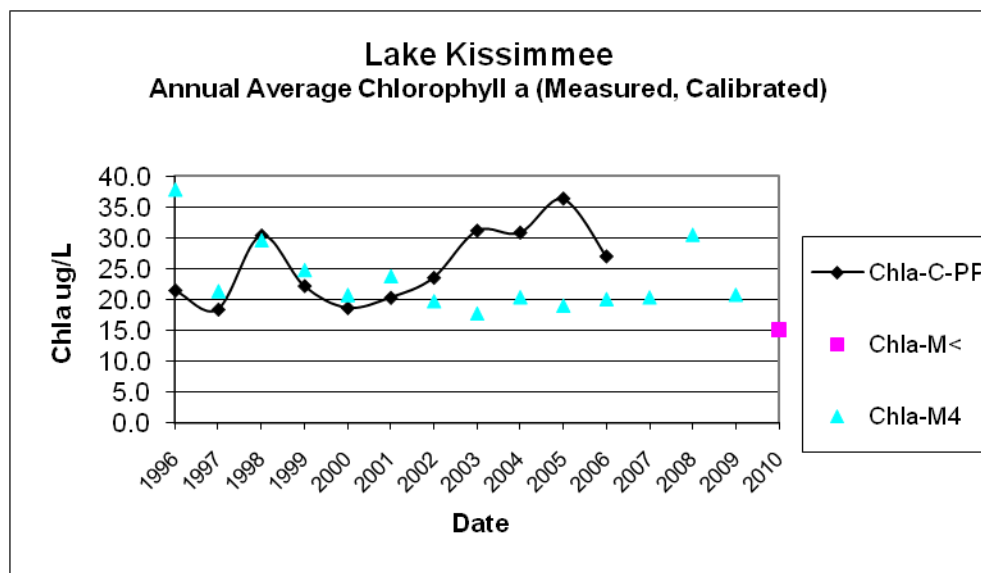


Figure 5.35 Corrected Chlorophyll  $a$  (ug/L) Annual Average Calibration

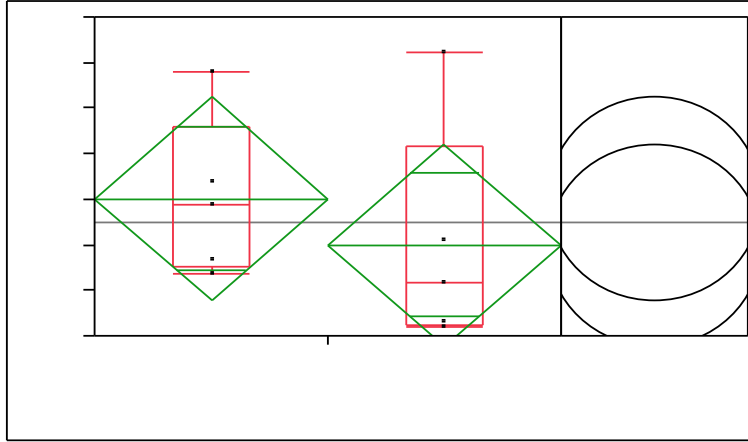


Table 5.23 Corrected Chlorophyll  $a$  Annual Average Calibration JMP Means Comparison

Means Comparisons		
Comparisons for all pairs using Tukey-Kramer HSD		
Abs(Dif)-LSD	$q^*$	Alpha
	2.30598	0.05
	Data-C	Model-C
Data-C	-6.27638	-4.23543
Model-C	-4.23543	-6.27638
Positive values show pairs of means that are significantly different.		
Level		Mean
Data-C	A	24.03
Model-C	A	21.99
Levels not connected by same letter are significantly different.		

Figure 5.36 Corrected Chlorophyll *a* (ug/L) Annual Average Validation

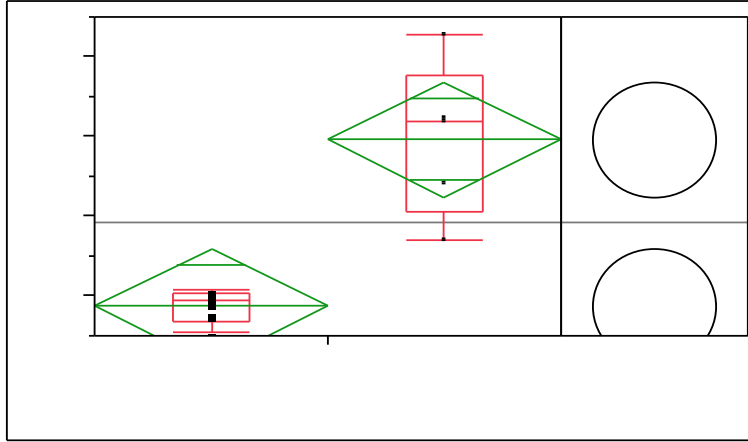


Table 5.24 Corrected Chlorophyll *a* Annual Average Validation JMP Means Comparison

Means Comparisons		
Comparisons for all pairs using Tukey-Kramer HSD		
	q*	Alpha
	2.30598	0.05
Abs(Dif)-LSD	<b>Model-V</b>	<b>Data-V</b>
Model-V	-5.11007	5.360988
Data-V	5.360988	-5.11007
Positive values show pairs of means that are significantly different.		
<b>Level</b>		<b>Mean</b>
Model-V	A	29.82
Data-V	B	19.35
Levels not connected by same letter are significantly different.		

Figure 5.37 Corrected Chlorophyll a (ug/L) Annual Average 1997 - 2006

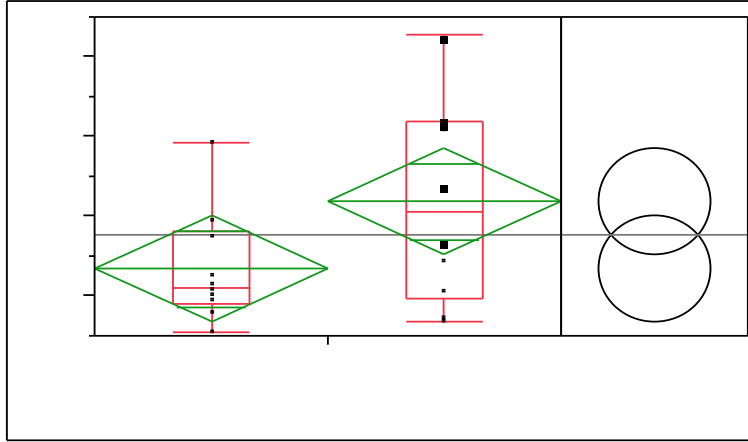


Table 5.25 Corrected Chlorophyll a Annual Average JMP Means Comparison 1997 - 2006

Means Comparisons		
Comparisons for all pairs using Tukey-Kramer HSD		
	q*	Alpha
Abs(Dif)-LSD	2.10092	0.05
	<b>Model-All</b>	<b>Data-All</b>
Model-All	-4.72137	-0.50632
Data-All	-0.50632	-4.72137

Positive values show pairs of means that are significantly different.

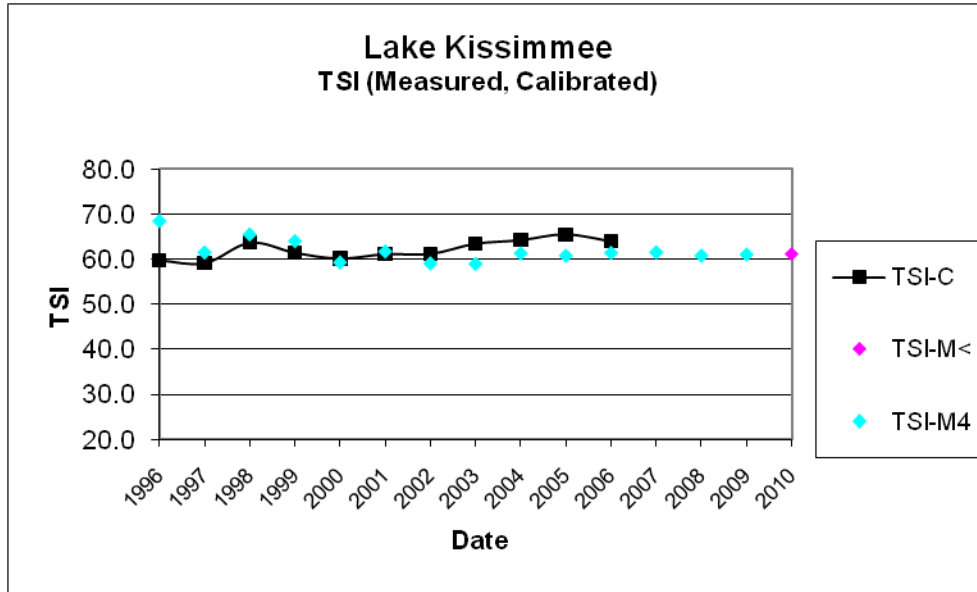
Level		Mean
Model-All	A	25.90
Data-All	A	21.69

Levels not connected by same letter are significantly different.

The results for the TSI calibration/validation for annual average conditions are depicted in **Figure 5.38**. This figure indicates that the model is reasonably predicting the pattern and magnitude in the annual variations of the TSI calculated from the measured data. **Figure 5.39** and **Table 5.26** comparing model annual average calibration predictions to the measured data, indicate the means are not significantly different at an alpha of 0.05. The annual average validation results (**Figure 5.40** and **Table 5.37**) comparing model predictions to the measured data, indicate the means are significantly different at an alpha of 0.05. The model mean was slightly (1.3 TSI units) under the measured mean for the calibration period and significantly over during the validation period (3.2 TSI units). The model calculated TN-TSI (**Figure 5.42** and **Table 5.29**, difference of 0.5) and TP-TSI (**Figure 5.43** and **Table 5.30**, difference of 0.3) for the validation period closely track the TN and TP TSIs calculated from the measured data (means were not significantly different at an alpha of 0.05). However, the model calculated CChla-TSI predictions are significantly greater than the CChla-TSI calculated from the measured data for the validation period. The inferred reasons for the significant difference in the CChla-TSI are given under the discussion of CChla results above. This information indicates that even though the model predictions for TSI during the validation period are significantly different from the one calculated from the measured data, the model predictions for the nutrient component of the TSI are not significantly different. As the TMDL will be based on the annual average (overall model period 1997 – 2006) response of TSI to the nutrient load reductions and subsequent changes in CChla, a comparison of means for this period was conducted. **Figure 5.41** and **Table 5.28** present the results for this comparison. While the model is slightly over predicting the TSI (1.0 TSI units), the means were not significantly different at an alpha of 0.05. Based on these results, the model is considered suitable for predicting annual average changes in TSI based on the lake response to changes in nutrient loadings over the ten-year period.

After reviewing all the results for TN, TP, chlorophyll *a*, and TSI, the DEP has determined that the model is suitably calibrated and validated for use in development of the nutrient TMDL.

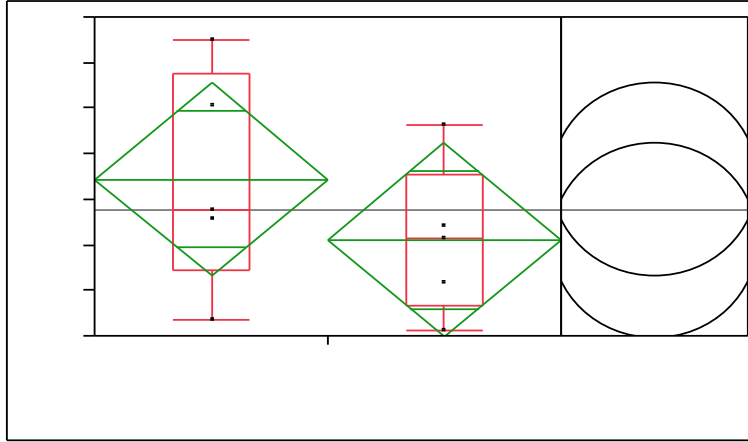
**Figure 5.38 TSI Annual Average Measured Data (1996 – 2009) and Simulated Results (1996 - 2006)**



The simulated year-by-year mass balance for TP in Lake Kissimmee is presented in **Table 5.31**. For each year, the table shows the sources of TP (positive values) to the lake and losses of TP from the lake (negative values), along with the net change in TP mass. Inflow from the upstream basins account for 69.1% of the TP load, the local subbasin accounts for 12.1%, flux from the lake bed 15.5%, and rainfall accounts for the remaining 3.3%. Overall, the model results show that about 81.3% of the TP load to the lake actually leaves the lake with the outflow, while 18.7% is removed through settling and transformation-uptake.

The simulated year-by-year mass balance for TN in Lake Kissimmee is presented in **Table 5.32**. For each year, the table shows the sources of TN (positive values) to the lake and losses of TN from the lake (negative values), along with the net change in TN mass. Inflow from the upstream basins account for 77.5% of the TN load, the local subbasin accounts for 15.1%, and rainfall accounts for 7.4%. Overall, the model results show that about 94.2% of the TN load to the lake actually leaves the lake with the outflow, while only 5.8% is removed through settling and transformation-uptake.

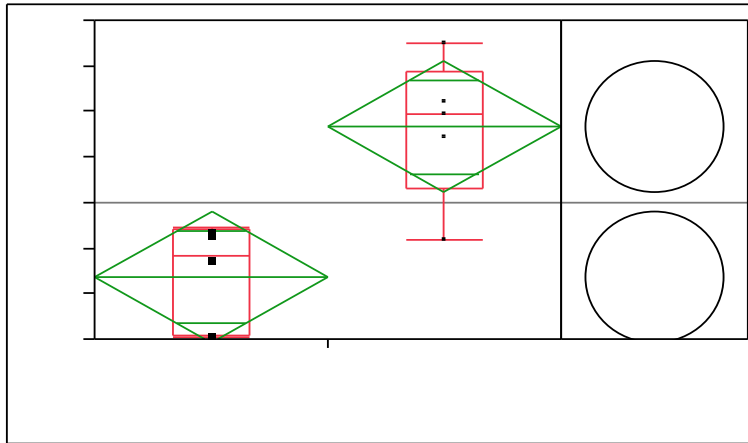
**Figure 5.39 TSI Annual Average Calibration**



**Table 5.26 TSI Annual Average Calibration JMP Means Comparison**

<b>Means Comparisons</b>		
<b>Comparisons for all pairs using Tukey-Kramer HSD</b>		
	<b>q*</b>	<b>Alpha</b>
	2.30598	0.05
<b>Abs(Dif)-LSD</b>		
Data-C	<b>Data-C</b>	<b>Model-C</b>
	-3.00669	-1.66272
Model-C	-1.66272	-3.00669
Positive values show pairs of means that are significantly different.		
<b>Level</b>		<b>Mean</b>
Data-C	A	62.4
Model-C	A	61.1
Levels not connected by same letter are significantly different.		

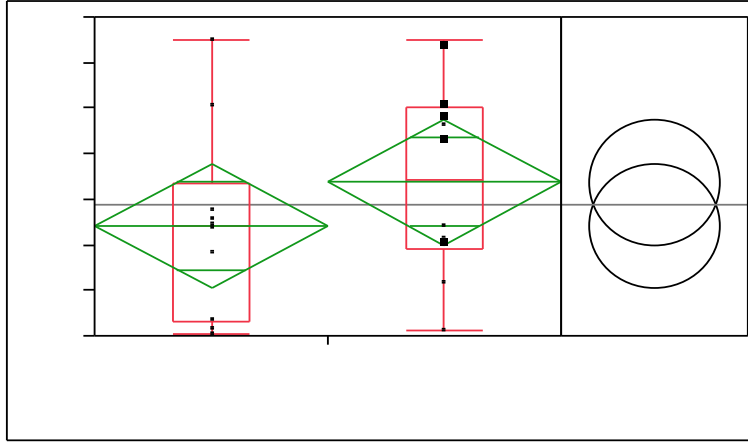
**Figure 5.40 TSI Annual Average Validation**



**Table 5.27 TSI Annual Average Validation JMP Means Comparison**

<b>Means Comparisons</b>		
<b>Comparisons for all pairs using Tukey-Kramer HSD</b>		
	<b>q*</b>	<b>Alpha</b>
	2.30598	0.05
Abs(Dif)-LSD	<b>Model-V</b>	<b>Data-V</b>
Model-V	-2.03953	1.244682
Data-V	1.244682	-2.03953
Positive values show pairs of means that are significantly different.		
<b>Level</b>		<b>Mean</b>
Model-V	A	63.6
Data-V	B	60.4
Levels not connected by same letter are significantly different.		

**Figure 5.41 TSI Annual Average 1997 -2006**



**Table 5.28 TSI Annual Average JMP Means Comparison 1997 - 2006**

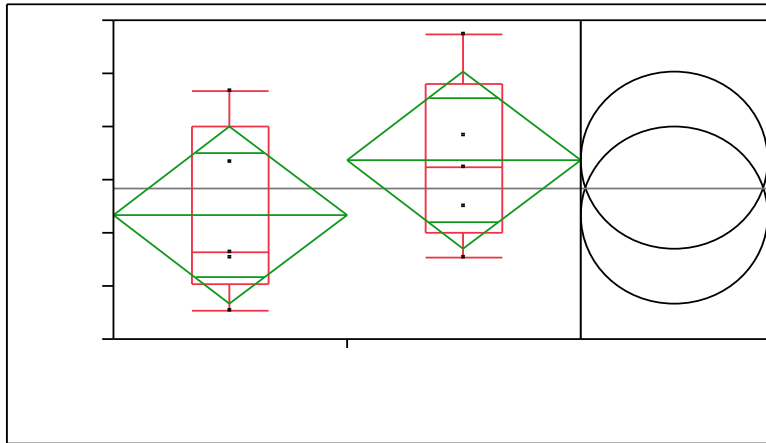
<b>Means Comparisons</b>		
<b>Comparisons for all pairs using Tukey-Kramer HSD</b>		
	<b>q*</b>	<b>Alpha</b>
	2.10092	0.05
Abs(Dif)-LSD	<b>Model-All</b>	<b>Data-All</b>
Model-All	-1.93965	-0.96953
Data-All	-0.96953	-1.93965

Positive values show pairs of means that are significantly different.

<b>Level</b>		<b>Mean</b>
Model-All	A	62.4
Data-All	A	61.4

Levels not connected by same letter are significantly different.

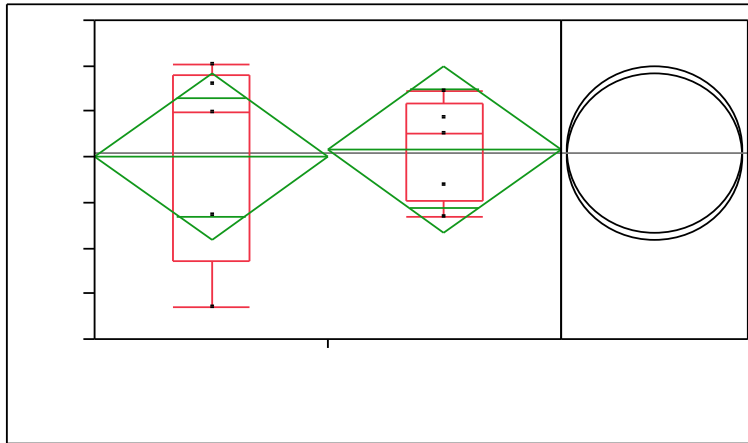
**Figure 5.42 TN-TSI Annual Average Validation**



**Table 5.29 TN-TSI Annual Average Validation JMP Means Comparison**

<b>Means Comparisons</b>		
<b>Comparisons for all pairs using Tukey-Kramer HSD</b>		
	<b>q*</b>	<b>Alpha</b>
	2.30598	0.05
<b>Abs(Dif)-LSD</b>	<b>Model-V</b>	<b>Data-V</b>
Model-V	-1.17626	-0.66127
Data-V	-0.66127	-1.17626
Positive values show pairs of means that are significantly different.		
<b>Level</b>	<b>Mean</b>	
Model-V A	61.2	
Data-V A	60.7	
Levels not connected by same letter are significantly different.		

**Figure 5.43 TP-TSI Annual Average Validation**



**Table 5.30 TP-TSI Annual Average Validation JMP Means Comparison**

<b>Means Comparisons</b>		
<b>Comparisons for all pairs using Tukey-Kramer HSD</b>		
	<b>q*</b>	<b>Alpha</b>
	2.30598	0.05
<b>Abs(Dif)-LSD</b>	<b>Model-V</b>	<b>Data-V</b>
	-5.17301	-4.81124
	-4.81124	-5.17301
Positive values show pairs of means that are significantly different.		
<b>Level</b>	<b>Mean</b>	
Model-V A	62.3	
Data-V A	62.0	
Levels not connected by same letter are significantly different.		

**Table 5.31 HSPF Simulated Total Phosphorus Budget for Lake Kissimmee from 1997 to 2006 in Pounds/Year**

Year	Baseflow	Estimated Regional GW	Interflow	Runoff	Total Subbasin Input	Inflow Tribs	Rainfall	Benthic release	Total Incoming	Settling	Outflow	Change
	TP lbs	TP lbs	TP lbs	TP lbs	TP lbs	TP lbs	TP lbs	TP lbs	TP lbs	TP lbs	TP lbs	TP lbs
1996	1905	10256	7947	3048	23156	115036	8797	42854	189843	-43094	-133664	13085
1997	1879	10199	7479	1494	21051	105593	9404	41700	177748	-36155	-134423	7170
1998	2703	10335	14326	2181	29545	234693	8371	42325	314934	-56313	-273120	-14499
1999	2687	10126	11080	2387	26280	114132	9511	42890	192813	-45898	-152863	-5948
2000	730	10340	1365	258	12692	50050	4783	40453	107979	-35604	-88627	-16252
2001	1297	10189	5295	989	17769	90460	7594	40953	156777	-39812	-120232	-3268
2002	2649	10018	10560	949	24176	173969	9346	42729	250220	-47895	-207013	-4687
2003	3206	10335	10884	4360	28785	239280	9121	42467	319654	-63113	-268517	-11976
2004	3258	10613	20012	34607	68490	448522	11514	44143	572669	-69518	-480287	22865
2005	5279	10625	26363	32654	74920	363338	13471	43787	495517	-74697	-422438	-1619
2006	1241	10643	9670	5175	26729	63057	6079	40791	136655	-51194	-113217	-27756
AVG97-06	2493.0	10342.2	11703.3	8505.4	33043.9	188309.4	8919.5	42223.9	272496.7	-52019.9	-226073.8	-5597.0
Percent	7.5	31.3	35.4	25.7	12.1	69.1	3.3	15.5	100	18.7	81.3	

<sup>1</sup> Inflows include surface and ground water.

<sup>2</sup> No data are available for potential sediment flux.

<sup>3</sup> Outflow is discharged to downstream basin (Kissimmee River).

**Table 5.32 HSPF Simulated Total Nitrogen Budget for Lake Kissimmee from 1997 to 2006 in Pounds/Year**

Year	Baseflow	Estimated Regional GW	Interflow	Runoff	Total Subbasin Input	Inflow Tribs	Rainfall	Benthic release	Total Inflow	Settling	Outflow	Change
	TN lbs	TN lbs	TN lbs	TN lbs	TN lbs	TN lbs	TN lbs	TN lbs	TN lbs	TN lbs	TN lbs	TN lbs
1996	39289	384610	68442	23081	515422	2292811	294517	0	3102749	-195192	-2994170	-86613
1997	38634	382450	63714	11227	496024	2082889	314819	0	2893732	-163761	-2624412	105559
1998	56468	387571	133643	16499	594181	3602051	280238	0	4476469	-255063	-4350039	-128633
1999	56119	379735	101610	18083	555547	2273960	318404	0	3147911	-207893	-2905148	34871
2000	14900	387749	10768	1880	415296	1168876	160139	0	1744311	-161266	-1759775	-176730
2001	26520	382069	44602	7461	460652	1927760	254241	0	2642654	-180326	-2389751	72577
2002	54901	375670	92731	7116	530418	3461204	312895	0	4304517	-216934	-4130979	-43396
2003	66393	387563	101058	33188	588202	4012382	305354	0	4905937	-285865	-4752024	-131951
2004	67801	397980	192821	264089	922690	6227935	385476	0	7536101	-314874	-7055146	166081
2005	110601	398429	249613	249176	1007819	5487450	450988	0	6946257	-338333	-6641340	-33416
2006	25770	399100	85177	39355	549403	1132278	203527	0	1885207	-231880	-1795893	-142566
AVG97-06	51810	387832	107574	64807	612023	3137678	298608	0	4048310	-235619	-3840451	-27760
Percent	8.5	63.4	17.6	10.6	15.1	77.5	7.4	0.0	100	5.8	94.2	

<sup>1</sup> Inflows include surface and ground water.

<sup>2</sup> No data are available for potential sediment flux.

<sup>3</sup> Outflow is discharged to downstream basin (Kissimmee River).

### 5.3 Background Conditions

HSPF was used to describe and evaluate the “natural land use background condition” for the Lake Kissimmee watershed. For this simulation, all current land uses were ‘reassigned’ to a mixture of Forest and Wetland. The current condition was maintained for all waterbody physical characteristics, sediment oxygen demand and phosphorus fluxes remain the same as in the calibrated model. From this point forward, the natural land use background will be referred to as “background.” As discussed earlier, for existing conditions, the threshold TSI value of 60 is exceeded in seven of the ten years of simulation, and the lake is considered co-limited by nitrogen and phosphorus in all years. Under the background conditions, the lake is considered P-limited with an average TN/TP ratio of 38.8. Based on the background model run results in **Table 5.33**, the pre-developed lake should have had annual average TP concentrations ranging from 0.029 mg/l – 0.034 mg/L, with a long-term average of 0.031 mg/L. The pre-developed annual average TN concentrations ranged between 1.05 mg/L and 1.40 mg/L with a long-term average of 1.19 mg/L. The pre-developed annual average chlorophyll *a* ranged from 6.5 ug/L – 13.6 ug/L with an average of 9.4 ug/L. The resulting annual average TSI values ranged between 49.8 and 56.6, with a long-term average of 52.8.

**Table 5.33 Background Land Use Model Results**

Year	TP (mg/l)	TN (mg/l)	Chl-a (ug/l)	TSI	TN/TP Ratio	Nutrient Limitation
1997	0.029	1.18	6.50	49.8	40.2	P-Limited
1998	0.030	1.11	9.91	53.2	36.5	P-Limited
1999	0.029	1.22	7.71	51.1	41.3	P-Limited
2000	0.030	1.31	6.57	50.2	43.7	P-Limited
2001	0.031	1.40	7.32	51.3	45.1	P-Limited
2002	0.029	1.27	8.98	51.9	43.9	P-Limited
2003	0.030	1.09	11.45	54.1	36.7	P-Limited
2004	0.033	1.14	13.11	56.2	34.9	P-Limited
2005	0.033	1.05	13.57	56.6	31.5	P-Limited
2006	0.034	1.16	9.12	54.0	34.0	P-Limited
Average	0.031	1.19	9.4	52.8	38.8	P-Limited

### 5.4 Selection of TMDL Target

It should be recognized that the direct application of background as the target TSI would not allow for any assimilative capacity. The IWR uses as one measure of impairment in lakes, a 10

unit change in TSI from “historical” levels. This 10 unit increase is assumed to represent the transition of a lake from one trophic state (say mesotrophic) to another nutrient enriched condition (eutrophic). The Department has assumed that allowing a 5 unit increase in TSI over the background condition would prevent a lake from becoming impaired (changing trophic states) and reserve 5 TSI units to allow for future changes in the basin and as part of the implicit margin of safety in establishing the assimilative capacity. The final target developed for restoration of Lake Kissimmee includes achieving a TSI of background plus 5 (57.8) and an average TN/TP ratio near 23.

Lakes Marian, Jackson, and Cypress all drain to Lake Kissimmee (**Figure 4.1**). Draft nutrient TMDLs (documents referenced in Section 1.3) have been developed for all three of these lakes. The Lake Marian TMDL proposes reductions of 50% for TN and 65% for TP. The Lake Jackson TMDL proposes reductions of 12% for TN and 51% for TP. The Lake Cypress TMDL proposes reductions of 7% for TN and 53% for TP. Once the target TSI of 57.8 was established for Lake Kissimmee, HSPF was rerun for existing conditions within the Lake Kissimmee sub-basin (no local subbasin reduction) and with the proposed reductions for Lakes Marian, Jackson, and Cypress watersheds. The model results (**Figure 5.44**) indicate that Lake Kissimmee will have a long-term (average of 1997 – 2006) TSI of 57.6 (0.2 TSI units below the target of 57.8, used as part of the Margin of Safety) if Lakes Marian, Jackson, and Cypress achieve their respective nutrient TMDLs. As shown of **Figure 5.44**, the modeled TMDL-TSI for 2000 (driest year) was slightly less than the background condition, while the TMDL-TSIs for all other years were between the calibrated model and the background condition, as expected. The TMDL is based on the 10-year average condition and the long-term average results for the TMDL condition did not result in water quality better than the background condition.

Implementing the load reductions proposed for lakes Marian, Jackson, and Cypress resulted in Lake Kissimmee achieving its target TSI (with a 0.2 TSI unit margin of safety) without any additional reductions in TN or TP. This TMDL will be expressed as the maximum allowable load from all watershed sources that Lake Kissimmee can assimilate and still meet the waterbody's designated uses.

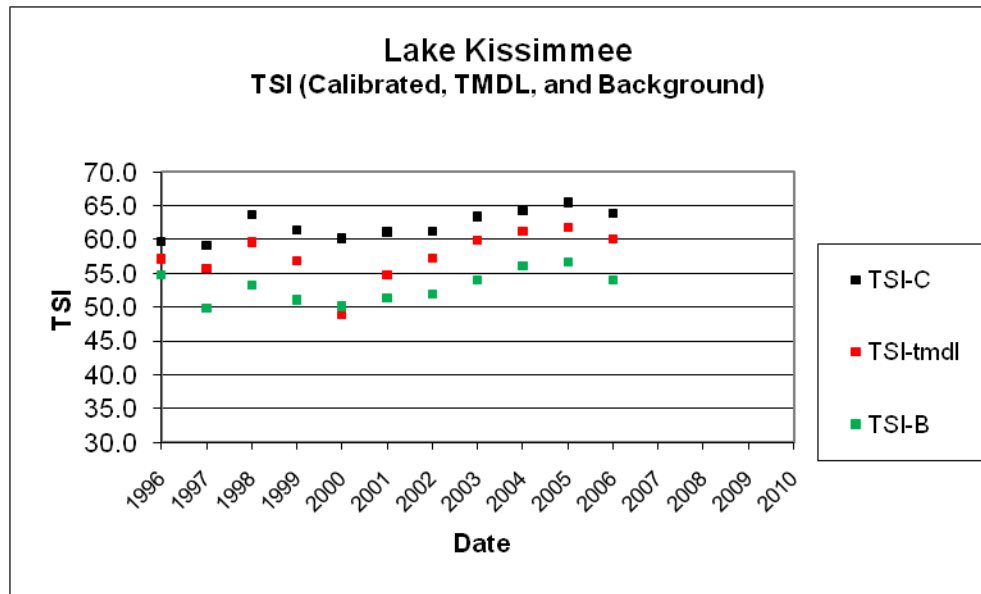
The 1997 – 2006 average TP existing loading from all sources of 272,497 lbs/yr is shown in **Tables 5.31 and 5.34**. The total existing watershed load of 221,353 lbs/yr is obtained by subtracting the loads from rainfall on the lake (8,919 lbs/yr) and benthic release (42,224 lbs/yr) from the total from all sources. The TP TMDL (watershed) in **Table 5.34** depicts the total allowable watershed load of 167,881 lbs/yr (without rainfall on lake or benthic release). The resulting percent reduction of 25% applied to the existing watershed sources will be applied to both the load allocation (LA) and stormwater Wasteload Allocation (MS4) components of the TMDL.

The 1997 – 2006 average TN existing loading from all sources of 4,048,310 lbs/yr is shown in **Tables 5.32 and 5.34**. The total existing watershed load of 3,749,701 lbs/yr is obtained subtracting the load from rainfall directly on the lake (298,608 lbs/yr) from the total from all sources. The TN TMDL (watershed) in **Table 5.34** depicts the total allowable watershed TN loading of 3,564,970 lbs/yr (without rainfall on the lake). The resulting percent reduction of 5% applied to the existing watershed sources will be applied to both the load allocation (LA) and stormwater Wasteload Allocation (MS4) components of the TMDL.

As the TMDL is based on the percent reduction in total watershed loading and any natural landuses are held harmless, the percent reductions for the anthropogenic sources may be greater than those proposed.

The goal of the TMDL is to achieve and maintain an average lake TSI of no greater than 57.8. As noted above, reductions in loading to Lake Kissimmee equivalent to those proposed in the TMDLs for Lakes Marian, Jackson, and Cypress, would result in a long-term TSI of 57.6 for Lake Kissimmee. Additionally, combinations of CChla, TN, and TP concentrations in the lake other than those derived from the model results (CChla of 18.3 ug/L, TN of 1.23 mg/L, and TP of 0.054 mg/L) could still result in a TSI less than 57.8 and successful restoration of the lake. The modeled in-lake concentrations (based on watershed loadings and model in-lake processes) have resulted in just one possible combination. Maintaining the long-term annual average loadings for TP and TN established in this TMDL should result in attaining the TMDL target TSI of 57.8.

Figure 5.44 TSI for TMDL, Calibrated Model, and Background+5 TSI Units



**Table 5.34 Existing and TMDL Watershed TN and TP Loads and Percent Reductions Average of 1997 – 2006 Model Years**

Condition	Year	Baseflow (lbs/yr) (1)	Interflow (lbs/yr)	Runoff (lbs/yr)	Rainfall (lbs/yr)	Benthic Release (lbs/yr)	Total Upstream (lbs/yr)	Total Inflow (lbs/yr) (2)
TP-Existing Total	AVG 97-06	12,835.2	11,703.3	8,505.4	8,919.5	42,223.9	188,309.4	272,497
TP-Existing Watershed	AVG 97-06	12,835.2	11,703.3	8,505.4			188,309.4	221,353
TP-TMDL Total	AVG 97-06	12,835.2	11,703.3	8,505.4	8,919.5	42,223.9	134,838	219,025
TP-TMDL watershed	AVG 97-06	12,835.2	11,703.3	8,505.4			134,838	167,881
TP TMDL %Reduction	AVG 97-06							25%
TN-Existing Total	AVG 97-06	439,642	107,574	64,807	298,608	0	3,137,678	4,048,310
TN-Existing Watershed	AVG 97-06	439,642	107,574	64,807			3,137,678	3,749,701
TN-TMDL Total	AVG 97-06	439,642	107,574	64,807	298,608	0	2,952,947	3,863,578
TN-TMDL Watershed	AVG 97-06	439,642	107,574	64,807			2,952,947	3,564,970
TN TMDL %Reduction	AVG 97-06							5%

(1) Includes HSPF baseflow load and load from estimated ground water.

(2) TMDL based on watershed loadings. Watershed load does not include load from the benthic flux or rainfall directly on the lake. The loads were rounded to a whole number. Percent reductions rounded up.

### 5.5 Critical Conditions

The estimated assimilative capacity was based on annual average conditions (i.e., values from all four seasons in each calendar year) rather than critical/seasonal conditions because (a) the methodology used to determine the assimilative capacity does not lend itself very well to short-term assessments, (b) the Department is generally more concerned with the net change in overall primary productivity in the segment, which is better addressed on an annual basis, and (c) the methodology used to determine impairment in lakes is based on an annual average and requires data from all four quarters of a calendar year.

## Chapter 6: DETERMINATION OF THE TMDL

### 6.1 Expression and Allocation of the TMDL

A TMDL can be expressed as the sum of all point source loads (wasteload allocations or WLAs), nonpoint source loads (load allocations or LAs), and an appropriate margin of safety (MOS) that takes into account any uncertainty about the relationship between effluent limitations and water quality:

As mentioned previously, the WLA is broken out into separate subcategories for wastewater discharges and stormwater discharges regulated under the NPDES Program:

$$\text{TMDL} \cong \sum \text{WLAs}_{\text{wastewater}} + \sum \text{WLAs}_{\text{NPDES Stormwater}} + \sum \text{LAs} + \text{MOS}$$

It should be noted that the various components of the TMDL equation may not sum up to the value of the TMDL because a) the WLA for NPDES stormwater is typically based on the percent reduction needed for nonpoint sources and is accounted for within the LA, and b) TMDL components can be expressed in different terms [for example, the WLA for stormwater is typically expressed as a percent reduction and the WLA for wastewater is typically expressed as a mass per day].

WLAs for stormwater discharges are typically expressed as “percent reduction” because it is very difficult to quantify the loads from MS4s (given the numerous discharge points) and to distinguish loads from MS4s from other nonpoint sources (given the nature of stormwater transport). The permitting of stormwater discharges is also different than the permitting of most wastewater point sources. Because stormwater discharges cannot be centrally collected, monitored and treated, they are not subject to the same types of effluent limitations as wastewater facilities, and instead are required to meet a performance standard of providing treatment to the “maximum extent practical” through the implementation of Best Management Practices.

This approach is consistent with federal regulations [40 CFR § 130.2(I)], which state that TMDLs can be expressed in terms of mass per time (e.g. pounds per day), toxicity, or **other appropriate measure**. The NPDES Stormwater WLA and Load Allocation (LA) are expressed as a percent reduction in the stormwater from these areas. The TMDL for Lake Kissimmee is expressed in terms of pounds per year and represents the long-term annual average load of TN and TP from all watershed sources that the waterbody can assimilate and maintain the Class III narrative nutrient criterion (**Table 6.1**).

**Table 6.1 Lake Kissimmee TMDL Load Allocations**

WBID	Parameter	WLA		LA (% reduction)	MOS	TMDL (lbs/year) (A)
		Wastewater (lbs/year)	Stormwater (% reduction) (A)			
3183B	TN	NA	5	5	Implicit	3,564,970
3183B	TP	NA	25	25	Implicit	167,881

(A) Allowable load from all watershed sources

The LA and TMDL daily load for TN is 9,767 lbs/day; for TP 459 lbs/day

These reductions resulted in long-term average lake concentrations of 0.054 mg/L for TP, 1.23 mg/L for TN, and 18.3 ug/L for chlorophyll *a* with an average TN/TP ratio greater than 23.

## 6.2 Load Allocation (LA)

Because the exact boundaries between those areas of the watershed covered by the WLA allocation for stormwater and the LA allocation are not known, both the LA and the WLA for stormwater will receive the same percent reduction. The LA is a 25% reduction in TP and a 5% reduction in TN of the total nonpoint source watershed loadings from the period 1997 - 2006. As the TMDL is based on the percent reduction in total watershed loading and any natural landuses are held harmless, the percent reductions for the anthropogenic sources may be greater. It should be noted that the LA may include loading from stormwater discharges regulated by the Department and the Water Management District that are not part of the NPDES Stormwater Program (**see Appendix A**).

## 6.3 Wasteload Allocation (WLA)

### NPDES Wastewater Discharges

As noted in Chapter 4, Section 4.2.1, there are no active National Pollutant Discharge Elimination System (NPDES) permitted facilities located within the Lake Kissimmee watershed that discharge surface water within the watershed. Therefore, the  $WLA_{wastewater}$  for the Lake Kissimmee TMDL is not applicable because there are no wastewater or industrial wastewater NPDES facilities that discharge directly to Lake Kissimmee.

### NPDES Stormwater Discharges

The stormwater collection systems in the Lake Kissimmee watershed, which are owned and operated by Polk County in conjunction with the Florida Department of Transportation (FDOT) District 1, are covered by NPDES Phase I MS4 permit number FLS000015. The collection systems which are owned and operated by Osceola County and the City of St. Cloud, are covered by NPDES Phase II MS4 permit number FLR04E012. The collection system for the City of Orlando is covered by NPDES Phase I permit number FLS000014. The collections systems for Orange County and the City of Belle Isle are covered by NPDES Phase 1 permit number FLS000011. The collection system for the city of Kissimmee is covered by NPDES Phase II permit number FLR04E64. The collection system for the Florida Department of Transportation District 5 is covered by NPDES permit number FLR04E024. The collections systems for the Florida Turnpike are covered by NPDES permit number FLR04E049. The wasteload allocation for stormwater discharges is a 25% reduction in TP and a 5% reduction in

TN of the total watershed loading from the period 1997-2006, which are the required percent reductions in stormwater nonpoint sources. It should be noted that any MS4 permittee will only be responsible for reducing the anthropogenic loads associated with stormwater outfalls for which it owns or otherwise has responsible control, and is not responsible for reducing other nonpoint source loads within its jurisdiction. As the TMDL is based on the percent reduction in total watershed loading and any natural landuses are held harmless, the percent reduction for just the anthropogenic sources may be greater.

#### **6.4 Margin of Safety (MOS)**

TMDLs must address uncertainty issues by incorporating a MOS into the analysis. The MOS is a required component of a TMDL and accounts for the uncertainty about the relationship between pollutant loads and the quality of the receiving waterbody [Clean Water Act, Section 303(d)(1)(c)]. Considerable uncertainty is usually inherent in estimating nutrient loading from nonpoint sources, as well as predicting water quality response. The effectiveness of management activities (e.g., stormwater management plans) in reducing loading is also subject to uncertainty.

The MOS can either be implicitly accounted for by choosing conservative assumptions about loading or water quality response, or explicitly accounted for during the allocation of loadings. Consistent with the recommendations of the Allocation Technical Advisory Committee (Florida Department of Environmental Protection, February 2001), an implicit margin of safety (MOS) was used in the development of the Lake Kissimmee TMDL. An implicit MOS was used because the TMDL was based on the conservative decisions associated with a number of the modeling assumptions and allowing for only a 5 TSI unit increase above background conditions in determining the assimilative capacity (i.e., loading and water quality response) for Lake Kissimmee.

## Chapter 7: NEXT STEPS: IMPLEMENTATION PLAN DEVELOPMENT AND BEYOND

### 7.1 Basin Management Action Plan

Following the adoption of these TMDLs by rule, the Department will determine the best course of action regarding their implementation. Depending on the pollutant(s) causing the waterbody impairment and the significance of the waterbody, the Department will select the best course of action leading to the development of a plan to restore the waterbody. Often this will be accomplished cooperatively with stakeholders by creating a Basin Management Action Plan, referred to as the BMAP. BMAPs are the primary mechanism through which TMDLs are implemented in Florida (see Subsection 403.067[7], F.S.). A single BMAP may provide the conceptual plan for the restoration of one or many impaired waterbodies.

If the Department determines that a BMAP is needed to support the implementation of these TMDLs, a BMAP will be developed through a transparent, stakeholder-driven process intended to result in a plan that is cost-effective, technically feasible, and meets the restoration needs of the applicable waterbodies.

Once adopted by order of the Department Secretary, BMAPs are enforceable through wastewater and municipal stormwater permits for point sources and through BMP implementation for nonpoint sources. Among other components, BMAPs typically include the following:

- *Water quality goals (based directly on the TMDLs);*
- *Refined source identification;*
- *Load reduction requirements for stakeholders (quantitative detailed allocations, if technically feasible);*
- *A description of the load reduction activities to be undertaken, including structural projects, nonstructural BMPs, and public education and outreach;*
- *A description of further research, data collection, or source identification needed in order to achieve the TMDLs;*
- *Timetables for implementation;*
- *Implementation funding mechanisms;*
- *An evaluation of future increases in pollutant loading due to population growth;*
- *Implementation milestones, project tracking, water quality monitoring, and adaptive management procedures; and*
- *Stakeholder statements of commitment (typically a local government resolution).*

BMAPs are updated through annual meetings and may be officially revised every five years. Completed BMAPs in the state have improved communication and cooperation among local stakeholders and state agencies; improved internal communication within local governments; applied high-quality science and local information in managing water resources; clarified the obligations of wastewater point source, MS4, and non-MS4 stakeholders in TMDL implementation; enhanced transparency in the Department's decision making; and built strong

relationships between the Department and local stakeholders that have benefited other program areas.

## 7.2 Other TMDL Implementation Tools

However, in some basins, and for some parameters, particularly those with fecal coliform impairments, the development of a BMAP using the process described above will not be the most efficient way to restore a waterbody, such that it meets its designated uses. This is because fecal coliform impairments result from the cumulative effects of a multitude of potential sources, both natural and anthropogenic. Addressing these problems requires good old-fashioned detective work that is best done by those in the area.

A multitude of assessment tools is available to assist local governments and interested stakeholders in this detective work. The tools range from the simple (such as Walk the WBIDs and GIS mapping) to the complex (such as bacteria source tracking). Department staff will provide technical assistance, guidance, and oversight of local efforts to identify and minimize fecal coliform sources of pollution. Based on work in the Lower St Johns River tributaries and the Hillsborough Basin, the Department and local stakeholders have developed a logical process and tools to serve as a foundation for this detective work. In the near future, the Department will be releasing these tools to assist local stakeholders with the development of local implementation plans to address fecal coliform impairments. In such cases, the Department will rely on these local initiatives as a more cost-effective and simplified approach to identify the actions needed to put in place a road map for restoration activities, while still meeting the requirements of Subsection 403.067(7), F.S.

## References

---

- Bicknell, B. R., Imhoff, J. C., Kittle, J. L., Donigian, A. S., Jr. and Johanson, R. C. 2001. *Hydrologic Simulation Program-Fortran, User's manual for Release 12*. U.S. Environmental Protection Agency, EPA/600/R-97/080, Environmental Research Laboratory, Athens, GA.
- Carlson, Robert E. 1977. *A Trophic State Index for Lakes*. Limnology and Oceanography. 22: 361-369.
- CDM, 2002. *Northern Coastal Basin Watersheds Hydrology Model Development : Pellicer Creek Planning Unit 9B*. Prepared for the St. Johns River Water Management District, Palatka, FL.
- CDM 2003. *Framework Model of the Upper St. Johns River Basin: Hydrology and Hydraulics, October 2003*. Prepared for the St. Johns River Water Management District, Palatka, FL.
- CDM, 2008. *Kissimmee River Watershed TMDL Model Development Report Volumes 1 and 2*. Prepared for the Florida Department of Environmental Protection
- Florida Department of Environmental Protection, February 2001. *A Report to the Governor and the Legislature on the Allocation of Total Maximum Daily Loads in Florida*. Florida Department of Environmental Protection, Allocation Technical Advisory Committee, Division of Water Resource Management, Bureau of Watershed Management, Tallahassee, Florida.
- , April 2001. Chapter 62-302, *Surface Water Quality Standards*, Florida Administrative Code (F.A.C.), Florida Department of Environmental Protection, Division of Water Resource Management, Bureau of Watershed Management, Tallahassee, Florida.
- , April 2001. *Chapter 62-303, Identification of Impaired Surface Waters Rule (IWR), Florida Administrative Code*. Florida Department of Environmental Protection, Division of Water Resource Management, Bureau of Watershed Management, Tallahassee, Florida.
- , June 2004. Division of Water Resource Management, Bureau of Information Systems, Geographic Information Systems Section, Florida Department of Environmental Protection, Tallahassee, Florida. Available at <http://www.dep.state.fl.us/gis/contact.htm>
- Florida Department of Health. Florida Department of Health web site. Available at <http://www.doh.state.fl.us/>; or <http://www.doh.state.fl.us/environment/OSTDS/statistics/ostdsstatistics.htm>.
- Florida Department of Transportation, 1999. *Florida Land Use, Cover and Forms Classification System (FLUCCS)*. Florida Department of Transportation Thematic Mapping Section.
- FWRA, 1999. *Florida Watershed Restoration Act*, Chapter 99-223, Laws of Florida.
- Hartigan, J.P., T.F. Quasebarth and E. Southerland, 1983 (A). *Calibration of NPS Loading Factors*. ASCE Journal of Environmental Engineering, Vol. 109, No. 6.

Hartigan, J.P., J.A. Friedman and E. Southerland, 1983 (B). *Post-Audit of Lake Model Used for NPS Management*. ASCE Journal of Environmental Engineering, Vol. 109, No. 6.

National Weather Service, 2004. National Weather Service, National Climatic Data Center, Climate Interactive Rapid Retrieval User System (CIRRUS) Database hosted by the Southeast Regional Climate Center web site. Available at <http://www.dnr.state.sc.us/pls/cirrus/cirrus.login>.

NVPDC, 1983 (primary author J.P. Hartigan). *Chesapeake Bay Basin Model Final Report*. Prepared for the U.S. Environmental Protection Agency Chesapeake Bay Program, Annapolis, MD.

NVPDC, 1986 (primary author R.A. Wagner). *Reverification of Occoquan Basin Computer Model: Post-Audit No. 2 with 1982-1984 Monitoring Data*. Prepared for the Occoquan Basin Nonpoint Pollution Management Program.

Over, T.M., Murphy, E.A., Ortel, T.W., and Ishii, A.L., 2007, *Comparison between*

SFWMD, 2001. *Upper Kissimmee Chain of Lakes Routing Model, Appendix B* (PBSJ, XPSofWare, and SFWMD, 2001

URS Greiner, 1998. *Basin Planning for Boggy Creek and Lake Hart Watersheds, Final Report*. Prepared for Stormwater Management Department, Public Works Division, Board of County Commissioners, Orange County, FL.

URS 2006, *Model ID & Acquisition TM for the Florida Department of Environmental Protection and Center for Environmental Studies Florida Atlantic University*.

U. S. Census Bureau Web Site. 2008. Available at [http://www.census.gov/; or http://factfinder.census.gov/servlet/GCTTable?\\_bm=y&-geo\\_id=04000US12&-box\\_head\\_nbr=GCT-PH1&-ds\\_name=DEC\\_2000\\_SF1\\_U&-lang=en&-format=ST-2&-sse=on](http://www.census.gov/; or http://factfinder.census.gov/servlet/GCTTable?_bm=y&-geo_id=04000US12&-box_head_nbr=GCT-PH1&-ds_name=DEC_2000_SF1_U&-lang=en&-format=ST-2&-sse=on).

U. S. Environmental Protection Agency, April 1991. *Guidance for Water Quality – Based Decisions: The TMDL Process*. U. S. Environmental Protection Agency, Office of Water, Washington, D.C. EPA-440/4-91-001.

—, November 1999. *Protocol for Developing Nutrient TMDLs*. U. S. Environmental Protection Agency, Office of Water, Washington, D.C. EPA841-B-99-007.

—, 2000. *EPA BASINS Technical Note 6: Estimating Hydrology and Hydraulic Parameters for HSPF*.

—, 2001. *Better Assessment Science Integrating Point & Non-point Sources BASINS version 3.0 User Manual*, Electronic File, <http://www.epa.gov/waterscience/basins/bsnsdocs.html>, Accessed June 2007.

—, July 2003. *40 CFR 130.2(l)*, Title 40 – Protection of the Environment, Chapter I – U.S. Environmental Protection Agency, Part 130 – Water Quality Planning and Management, U.S. Environmental Protection Agency, Washington, D.C.

USGS, 2002. *Simulation of Runoff and Water Quality for 1990 and 2008 Land-Use Conditions in the Reedy Creek Watershed, East-Central Florida*. Prepared in cooperation with the Reedy Creek Improvement District.

## Appendices

---

### Appendix A: Background Information on Federal and State Stormwater Programs

In 1982, Florida became the first state in the country to implement statewide regulations to address the issue of nonpoint source pollution by requiring new development and redevelopment to treat stormwater before it is discharged. The Stormwater Rule, as authorized in Chapter 403, F.S., was established as a technology-based program that relies on the implementation of BMPs that are designed to achieve a specific level of treatment (i.e., performance standards) as set forth in Chapter 62-40, F.A.C.

The rule requires the state's water management districts (WMDs) to establish stormwater pollutant load reduction goals (PLRGs) and adopt them as part of a SWIM plan, other watershed plan, or rule. Stormwater PLRGs are a major component of the load allocation part of a TMDL. To date, stormwater PLRGs have been established for Tampa Bay, Lake Thonotosassa, the Winter Haven Chain of Lakes, the Everglades, Lake Okeechobee, and Lake Apopka. To date, no PLRG has been developed for Lake Kissimmee.

In 1987, the U.S. Congress established Section 402(p) as part of the federal Clean Water Act Reauthorization. This section of the law amended the scope of the federal NPDES permitting program to designate certain stormwater discharges as "point sources" of pollution. The EPA promulgated regulations and began implementation of the Phase I NPDES stormwater program in 1990. These stormwater discharges include certain discharges that are associated with industrial activities designated by specific Standard Industrial Classification (SIC) codes, construction sites disturbing five or more acres of land, and master drainage systems of local governments with a population above 100,000, which are better known as municipal separate storm sewer systems (MS4s). However, because the master drainage systems of most local governments in Florida are interconnected, the EPA implemented Phase I of the MS4 permitting program on a countywide basis, which brought in all cities (incorporated areas), Chapter 298 urban water control districts, and the Florida Department of Transportation throughout the fifteen counties meeting the population criteria. The Department received authorization to implement the NPDES stormwater program in 2000.

An important difference between the NPDES and other state stormwater permitting programs is that the NPDES program covers both new and existing discharges, while the other state programs focus on new discharges. Additionally, Phase II of the NPDES Program, implemented in 2003, expands the need for these permits to construction sites between one and five acres, and to local governments with as few as 1,000 people. While these urban stormwater discharges are now technically referred to as "point sources" for the purpose of regulation, they are still diffuse sources of pollution that cannot be easily collected and treated by a central treatment facility similar to other point sources of pollution, such as domestic and industrial wastewater discharges. It should be noted that all MS4 permits issued in Florida include a re-opener clause that allows permit revisions to implement TMDLs when the implementation plan is formally adopted.

## **Appendix B: Electronic Copies of Measured Data and CDM, 2008 Report for Lake Kissimmee TMDL**

All information gathered by CDM and the HSPF model setup, calibration/validation, are contained within a Report titled "Kissimmee River Watershed TMDL Model Development Report January 2008" (CDM, 2008) and is available upon request (~100 megabytes on disk). Lake Kissimmee is included in the HSPF model project termed UKL\_Open.UCI. The CDM, 2008 report and all data used in the Lake Kissimmee TMDL report is available upon request. Please contact the individual listed below to obtain this information.

Douglas Gilbert, Environmental Manager  
Florida Department of Environmental Protection  
Bureau of Watershed Management  
Watershed Assessment Section  
2600 Blair Stone Road, Mail Station 3555  
Tallahassee, FL 32399-2400  
douglas.gilbert@dep.state.fl.us  
Phone: (850) 245-8450; Suncom: 205-8450  
Fax: (850) 245-8536

## Appendix C: HSPF Water Quality Calibration Values for Lake Kissimmee

HSPF Variable	Lake Jackson
<b>Water Temperature</b>	
CFSAEX	0.48
KATRAD	9.37
KCOND	6.12
KEVAP	2.24
<b>Total Suspended Solids</b>	
KSAND	6
EXPSND	1.5
W	1.0E-05
TAUCD	0.02
TAUCS	0.32
M	1.2
W	1.6E-06
TAUCD	0.02
TAUCS	0.46
M	1.2

<b>Dissolved Oxygen and Oxygen Demand</b>	
KBOD20	0.0012
TCBOD	1.037
KODSET	0
BENOD	8.4
TCBEN	1.037
REAKT (2)	---
REAKT (3)	---
EXPRED	---
EXPREV	---
TCGINV	1.024

<b>NUTRX Module</b>	
KTAM20	0.003
TCNIT	1.07
BrTam	0.00
BrPo4	0.014

<b>PLANK Module</b>	
RATCLP	2.25
NONREF	0.75
ALNPR	0.65
EXTB	0.45
MALGR	0.108
CMMLT	0.033
CMMN	0.045
CMMNP	0.028
CMMP	0.015
TALGRH	95
TALGRL	43
TALGRM	85
ALR20	0.003
ALDH	0.008
ALDL	0.0024
CLALDH	60
PHYSET	0.0050
REFSET	0.0
CVBO	1.31
CVBPC	106
CVBPN	10
BPCNTC	49

## Appendix D: Raw Data for Lake Kissimmee

### Remark Codes

- + is where TN was calculated from component parts (NO<sub>2</sub>+3 + ammonia + organic)
- & For CChla result reported was less than detection limit of 1.0 ug/L and assigned a value of 1.0 ug/L
- A Value is arithmetic mean of two or more determinations.
- I Value is between the method detection limit and practical quantitation limit
- J Value is estimated
- Q sample held beyond holding time
- T Value is less than the method detection limit for information only
- U Compound analysed but not detected, used 0.5 of MDL as noted

Due to the large volume of raw data, Appendix D is contained in a separate document.

