

**ELECTRONIC REPORTING
FILE SPECIFICATION GUIDE
2011 HAZARDOUS WASTE
REPORT SUBMISSIONS**

CONTENTS

	<u>Page</u>
1.0 INTRODUCTION.....	1
1.1 OVERVIEW OF DOCUMENT.....	1
1.2 INTENDED AUDIENCE.....	1
1.3 HAZARDOUS WASTE REPORT FORMS.....	2
1.4 DATA FILES.....	2
1.5 QUESTIONS / COMMENTS.....	3
2.0 CHANGES FROM PREVIOUS CYCLES.....	4
2.1 DATA COLLECTION CHANGES.....	4
2.2 CHANGES TO THE FILE SPECIFICATION STANDARDS.....	4
2.3 CHANGES TO THE DATA COLLECTION PROCESS.....	5
3.0 DATA SUBMISSION OVERVIEW.....	6
3.1 DATA REQUIREMENTS.....	6
3.2 TESTING THE TRANSLATION.....	6
3.3 AMOUNT OF DATA IN A SINGLE SUBMISSION.....	7
3.4 SITE NOT USING THE <i>2011 HAZARDOUS WASTE REPORT, INSTRUCTIONS AND FORMS</i>	7
3.4.1 <i>Identify Sites</i>	7
3.4.2 <i>Access Equivalent Data</i>	8
3.4.3 <i>Data Quality/Equivalency</i>	9
3.4.4 <i>Write Translated Data to Flat Files</i>	9
4.0 TECHNICAL SPECIFICATIONS.....	9
4.1 INCLUDE IN NATIONAL REPORT FLAGS.....	9
4.2 STATE GENERATOR STATUS.....	10
4.3 RULES AND FORMAT CONVENTIONS REQUIRED FOR DATA FLAT FILES.....	10
4.3.1 <i>Alphanumeric Fields</i>	10
4.3.2 <i>Integer Fields</i>	10
4.3.3 <i>Fixed Decimal Fields</i>	11
4.3.4 <i>Sequence Number Fields</i>	11
4.3.5 <i>Negative Numbers</i>	12
4.4 INDICATING DON'T KNOW (DK) AND NOT APPLICABLE (NA).....	12
4.5 RECORD TERMINATION.....	12
4.6 EMPTY FIELDS.....	12
4.7 FLAT FILE HIERARCHY.....	12
4.8 CONFIDENTIAL BUSINESS INFORMATION (CBI).....	12
APPENDIX A - NATIONAL AND SYSTEM REQUIRED DATA ELEMENTS.....	1
A.1 NATIONAL DATA ELEMENTS.....	1
A.2 SYSTEM REQUIRED ELEMENTS.....	1
APPENDIX B - FLAT FILE SPECIFICATIONS.....	1
B.1 KEY FOR FLAT FILE TABLES.....	1
B.2 FLAT FILE NAMING CONVENTION.....	1
B.3 FLAT FILES.....	2
<i>FLAT FILE ID# - GM1</i>	3
<i>FLAT FILE ID# - GM2</i>	4
<i>FLAT FILE ID# - GM3</i>	5
<i>FLAT FILE ID# - GM4</i>	6
<i>FLAT FILE ID# - GM5</i>	7
<i>FLAT FILE ID# - WR1</i>	8

<i>FLAT FILE ID# - WR2</i>	9
<i>FLAT FILE ID# - WR3</i>	10
<i>FLAT FILE ID# - OII</i>	11
C.1 GENERIC DATA EDITS	13
C.4 FORM GM EDITS	13
C.5 FORM WR EDITS	15
APPENDIX D HAZARDOUS WASTE REPORT ANNOTATED FORMS	17
APPENDIX E - EPA ID CHECK DIGIT ROUTINE	1
E.1 CHARACTERISTICS OF AN EPA ID	1
E.2 PARTS OF AN EPA ID	1
E.3 MODULUS 10 CHECK DIGIT ROUTINE	1
E.4 ALTERNATE CHECK DIGIT ROUTINE	2
E.5 EXAMPLE CHECK DIGIT CALCULATIONS	2
APPENDIX F - Example Flat Files	F-1
APPENDIX G - Flat File Hierarchy	G-1

LIST OF EXHIBITS

Exhibit 2. Incorrect and Correct Integer Entries	11
Exhibit 3. Incorrect and Correct Fixed Decimal Entries	11

1.0 INTRODUCTION

This document describes the file specifications for reporting data for the 2011 Hazardous Waste Report (also called the Biennial Report). The material in this guide covers submissions by sites to states and regions using BRState software. The file specifications in this guide are intended to be used to cover submissions by individual reporting sites. Also, this guide is only intended to specify the file and data formats for the submission and is not intended to cover any procedural or programmatic issues.

This document is designed to be used in conjunction with the *2011 Hazardous Waste Report, Instructions and Forms*, EPA Form 8700-13A/B and is referenced throughout this document. You should have a complete copy of the *2011 Hazardous Waste Report, Instructions and Forms* in your possession while using this guide. Copies of the *2011 Hazardous Waste Report, Instructions and Forms* are available at <http://www.epa.gov/epaoswer/hazwaste/data/#brs>.

1.1 Overview of Document

The *File Specification Guide for 2011 Biennial Report Hazardous Waste Submissions* is divided into four sections:

Section 1 (Introduction) defines the intended audience for this guide, offers a brief description of the forms contained in the *2011 Hazardous Waste Report, Instructions and Forms*, and describes the general purpose and outline of this document.

Section 2 (Data Collection Changes) outlines the major changes to the file specifications from previous Biennial Report cycles.

Section 3 (Data Submission Overview) describes the overall characteristics for a data submission.

Section 4 (Technical Specifications) discusses the technical details of the data files and programs necessary for data submission.

Several appendices are included with this document. These appendices provide background material as well as detailed technical information necessary to properly prepare file submissions.

1.2 Intended Audience

The intended audience for this guide is any Site that is using its own software and procedures to extract hazardous waste data from a site system for submission to the State or Region for inclusion in the BRState Software database for the 2011 Hazardous Waste Report.

This document was written assuming the reader is 1) familiar with the *2011 Hazardous Waste Report, Instructions and Forms* and 2) understands basic computer concepts and terminology.

1.3 Hazardous Waste Report Forms

The *2011 Hazardous Waste Report, Instructions and Forms* capture information on the following forms:

RCRA Subtitle C Site Identification Form

The Site Identification Form collects information on the site completing the Biennial Report forms package. The form is divided into thirteen items, nine of which must be completed for the Hazardous Waste Report. Sites submit Site ID form information via the SI1, SI2, SI3, SI4, SI5, SI6, SI7 and SI9 flat files. It is strongly suggested that sites submit form SI on paper only or using BRState to create the flat files to submit with the paper printout. Either way, a Signed Dated paper copy must be included with the submission.

Form GM

Form GM is for reporting on-site hazardous waste generation, management and off-site shipment. Form GM is divided into three sections that document 1) the source, characteristics and quantity of hazardous waste generated; 2) the quantity of hazardous waste managed on-site along with the management method used; and 3) the quantity of hazardous waste shipped off-site for treatment, disposal, or recycling along with the off-site management method used. Sites submit GM form information via the GM1, GM2, GM3, GM4, and GM5 flat files.

Form WR

Form WR identifies hazardous wastes that were received from other hazardous waste sites and the method(s) used to manage them. Form WR is divided into three identical parts (i.e., waste blocks), labeled Waste 1, Waste 2, and Waste 3, that collect information on the quantities and characteristics of each hazardous waste received from an off-site source during 2011 and managed on-site. Sites submit WR form information via the WR1, WR2, and WR3 flat files.

Form OI

Form OI documents the names and addresses of off-site installations and transporters. OI file specifications have been included to facilitate loading the form IO data into the BRState Software State or Region database.

1.4 Data Files

Information gathered from the Hazardous Waste Report is submitted to the state or region via a series of flat files. Each form contains information that relates to the form in a one-to-one (1:1) relationship (e.g., Form GM, Section 1, Block D, source code). These data elements are captured in the primary flat file for that form (e.g., SI1, GM1, and WR1). Information that relates to the form in a many-to-one ($n:1$) relationship (e.g., Form GM, Section 1, Block B, EPA hazardous waste codes) are captured in secondary flat files (e.g., GM2-GM5, WR2-WR3).

The remainder of this document describes in detail the steps necessary to ensure a successful data submission including identifying what sites should be reported, the types of files that must be included with each submission and technical aspects of the file creation process.

Acceptance of electronic reporting varies from state to state. If you did not receive this document from the state environmental agency to which you are reporting, contact that agency and confirm their acceptance of electronic submissions.

The following procedures must be followed to ensure that the information is properly submitted:

- . Hazardous Waste Report Forms GM, WR, and OI may be submitted electronically. Form SI should be submitted on the printed form.
- . A submission may contain forms of one type in electronic format and forms of another type in paper format. For example, a facility could submit all WR forms in electronic format and all other form types on printed forms.
- . All pages of a specific form type (GM, WR, or OI) must be submitted in the same format. For example, if you choose to submit one GM form response electronically, then you must submit all GM forms electronically; if you submit one Form WR on a printed form, then you must submit all WR forms on printed forms.
- . A complete electronic submission for a particular Report form type (GM, WR, or OI) may not include all flat files for that form. For example, respondents submitting Form GM data electronically in a state requiring only EPA waste codes would omit the "G3" flat file from their electronic submission. This is because the "G3" file is used to store state hazardous waste codes only. Thus, files determined to be correctly null or empty should be omitted.
- . The submission package must contain the respondent's entire response to the *Report* including any printed forms. The paper SI form, which may also be submitted electronically, must be included.

The package should include:

- . The respondent's signed SI form. (all fields are now REQUIRED)
- . Photocopies of all forms not submitted electronically.
- . The electronic media containing the flat file submission.
- . Any other information or instructions regarding the electronic submission.
- .

1.5 Questions / Comments

Questions about this document should be directed to the appropriate State or EPA Regional personnel.

2.0 CHANGES FROM PREVIOUS CYCLES

2.1 Data Collection Changes

The EPA has made significant modifications to the Hazardous Waste Report for the 2011. For further details on these changes, please refer to page 2 of the *2011 Hazardous Waste Report, Instructions and Forms*.

2.2 Changes to the File Specification Standards

Because of the minor changes made to the 2011 Hazardous Waste Report Forms, EPA HQ is taking this opportunity to revise the flat file specifications to more closely reflect the current forms. This primarily involves removing data elements from the flat file specifications that are no longer collected.

Specific changes to the flat file definitions include (field numbers refer to the specifications defined in the *File Specification Guide 1999 Hazardous Waste Submission*):

- GM1 - Replaced *****OBSOLETE FIELD***** in position 8 with a new Waste Minimization field
 - This causes a field re-numbering but no position changes
- WR1 Moved field 11- **INCLUDE_IN_NATIONAL_REPORT** to the old position 8 *****OBSOLETE FIELD*****
 - This causes a field re-numbering and shifts the Description and Notes fields one position up (left)
- OI1 – No changes – No longer required for Florida

2.3 Changes to the Data Collection Process

Historically (BR cycles 1989, 1991, 1993, 1995, and 1997), EPA HQ provided the Biennial Reporting System (BRS) software to states and regions for use in processing Hazardous Waste Report submissions. Beginning with the 1999 Biennial Report cycle and continuing with the 2011 Biennial Report cycle, EPA HQ will not provide BRS software to the regions and states for Hazardous Waste Report submissions. States and regions are responsible for evaluating and procuring software to assist them in processing of Hazardous Waste Report submissions, by either developing software on their own, procuring software from commercial vendors, or procuring software from other States or regions.

3.0 DATA SUBMISSION OVERVIEW

3.1 Data Requirements

Three types of data elements are collected via the *2011 Hazardous Waste Report, Instructions and Forms*: 1) national; 2) shared; and 3) system required. All national and system required data elements must be included in the Hazardous Waste Report submission. A list of the data elements in the *2011 Hazardous Waste Report, Instructions and Forms* that are required to be provided are listed in Appendix A.

Reporters must provide data for the national and system required data elements. Flat files containing national data elements include:

- . Form Site ID data (RCRA Subtitle C Site Identification Form):
Flat Files S11- S1B (as required) – these should be submitted using suitable software like BRState since there is only one form.
- . Form GM data (Waste Generation and Management):
Flat Files GM1, GM2, GM4, and GM5.
- . Form WR data (Waste Received from Off-site):
Flat Files WR1, and WR2.

All data elements must be properly formatted and meet required data quality standards to be loaded into The BRState Software. The data quality standards for these elements are presented in Appendix C.

Appendix B contains the flat file specifications for all files (including the control file) needed to produce the Hazardous Waste Report data submission.

3.2 Testing the Translation

It is the responsibility of the site to produce a complete set of correctly formatted files of a given site for inclusion in the state, region, and EPA database. The BRState Software application can accommodate partial submissions containing all data for a given form.

The following steps are suggested in order to ensure that the data transfer process proceeds smoothly:

- . After the data have been written to the transfer media, the transfer media should be tested to ensure readability and correctness of the data.
- . If physical media is used for transferring the data, the media should be completely and accurately labeled. Any information or instruction required to correctly retrieve the flat files from the medium must also be included.
- . A backup copy of the data files should be retained as a record of the submission and for use in case the original submission is lost or damaged.
- . The submission package should be shipped by a traceable means that provides a return receipt. The electronic media should be isolated in packaging that will protect it from magnetic and/or static electric disturbance.

3.3 Amount of Data in a Single Submission

Each data submission must contain **all** data for the site for which data is being submitted. Each data submission will overwrite all existing data for the site in the BRState Software database.

3.4 Sites not using the *2011 Hazardous Waste Report, Instructions and Forms*

Translators are required to provide data equivalent to that collected by the *2011 Hazardous Waste Report, Instructions and Forms* (nationally required data elements and system required data elements). The following information is provided to help translators become familiar with the steps to ensure a successful data submission:

- . Identify information to be translated.
- . Access information that is equivalent to the *2011 Hazardous Waste Report* data.
- . Validate that the equivalent data conforms to the appropriate data quality standards.
- . Write translated data to appropriate flat files.
- . Load the translated flat files into BRState to verify that the translation and data are complete and correct.

3.4.1 Identify Sites

The reporter must submit information for sites required to file the *2011 Hazardous Waste Report, Instructions and Forms*. The criteria that defines these sites is presented on page i of the *2011 Hazardous Waste Report, Instructions and Forms* under "Sites Required to File the Hazardous Waste Report." Sites are not precluded from submitting information for sites not required to file the *2011 Hazardous Waste Report, Instructions and Forms*.

3.4.2 Access Equivalent Data

The national data elements for the sites being reported must be provided (see Appendix A for a complete list of national data elements). The translator site must identify the data elements and relationships in their system equivalent to the data elements/relationships represented by the flat file specifications provided in Appendix B. In addition, the translator must also provide all system required data elements for the data to be properly stored in The BRState Software.

The Form GM, Form WR and Form OI allow for multiple form submissions by a handler. Translator Sites must also accommodate multiple “forms” by handler as follows:

Form GM

Form GM collects data associated with a single reported waste. Translators must provide records in the GM1 - GM5 files for each waste generated or managed during the reporting cycle. Thus, each page number for the GM flat file records represents a **single** reported waste. All "GM" flat file records containing data associated with the same waste reported for the same EPA ID will have the same page number. Page number takes the value of "00001" for the first reported waste (Form GM) and is incremented by one (1) with each following reported waste.

Form WR

Form WR collects data associated with each reported waste received from off-site. Translators must provide records in the WR1 - WR3 files for each waste received from off-site. All "WR" flat file records containing data associated with the same received waste reported for the same handler will have the same page number. Page number takes the value of "00001" for the first received waste (Form WR), and is incremented by one (1) with each separate received waste reported. The sub-page number for Form WR data must always be assigned the value of “1”.

Form OI

Form OI collects data identifying handlers from whom waste was received and to whom waste was shipped and all transporters used to ship waste during the reporting cycle. These source, destination, and transporting entities are identified by their EPA ID, name, and address. The page number for the OI flat file records represents a single handler record. Page number takes the value of "00001" for the first handler record and is incremented by one (1) with each separate handler record reported. Form OI is no longer required for Florida reports.

3.4.3 Data Quality/Equivalency

The Site's translator data must provide an accurate representation of hazardous waste activity for that site. In addition, the translator's data must pass a minimum set of data edits (see Appendix C) in order to provide information comparable to data gathered with the *2011 Hazardous Waste Report, Instructions and Forms* and to be properly loaded into the BRState Software database. Data failing to conform to the appropriate data quality edits will result in the entire data submission being rejected.

A copy of the *2011 Hazardous Waste Report* forms annotated to show in which flat file each data element is located can be found in Appendix D. In addition, all codes used in the submission must conform to acceptable data values as specified in Appendix C.

3.4.4 Write Translated Data to Flat Files

Translator Sites must extract data from their site system, and re-produce the data in the flat file formats outlined in Appendix B. A complete translation effort may not necessarily include all flat files. For example, a translator submitting Form GM data is not required to include the "GM3" flat file (state waste codes) as this is shared data. However, the site is encouraged to include all shared data in the Hazardous Waste Report data submission.

The flat file specifications for the Hazardous Waste Report data is based on a series of parent-child relationships. A parent file (e.g., SI1, GM1, WR1) may have one or more child relationships with other flat files (SI2-SI9, GM2-GM5, WR2-WR3). Child records may not exist without the existence of the parent record (e.g., a record for site XYZ cannot exist in the GM2 file if a corresponding record does not exist in the GM1 file). Appendix G shows the parent-child relationships for all flat files comprising the Hazardous Waste Report data submission.

Data for a site should only be included in the Hazardous Waste Report data submission after all records for that site pass all appropriate edit checks. If a site's data is incomplete, then the site's information must not be included in the site's Hazardous Waste Report data submission. **It is not sufficient to eliminate the data element in error and submit the remainder of the site's data.**

4.0 TECHNICAL SPECIFICATIONS

This section contains the standards that must be met when producing flat files for the Hazardous Waste Report data submission. Failure to meet these specifications will result in the rejection of the flat files and failure to load the data into the BRState Software database.

4.1 Include in National Report Flags **

The SI1, GM1 and WR1 file specifications includes a field labeled INCLUDE_IN_NATIONAL_REPORT. The purpose of this field is to allow implementers to submit additional Biennial Report data (for purposes of data sharing) but keep that data from being included in the National Biennial Hazardous Waste Report. The field is defined as follows: If the INCLUDE_IN_NATIONAL_REPORT flag in the SI1 file is 'N' (No), then all the INCLUDE_IN_NATIONAL_REPORT flags, for the site, must also equal 'N' (No) else the submission will be in error. If the INCLUDE_IN_NATIONAL_REPORT flag in the SI1 file is 'Y' (Yes), implementers may set the flag in the GM1 and WR1 file as either 'Y' (Yes) or 'N' (No) indicating whether that particular waste should be included in the National Biennial Hazardous Waste Report. It is anticipated that many implementers will default the value for these flags to 'Y' (Yes) in all cases, however, the specific implementation of how these flags are populated is determined by the implementer (State).

4.2 State Generator Status

Starting with the 2011 Biennial Report cycle, implementers are required to furnish both the State specific generator status and the federal generator status for each site in their submission. Appropriate fields are included in the SII file specification for this purpose. It is anticipated that many States whose regulations closely match the federal regulations, either by reference or by inclusion, will choose for the values of these fields to be the same. The method to populate these fields is determined by the implementer, however, both fields must be provided or the submission will be rejected.

4.3 Rules and Format Conventions Required for Data Flat Files

The following sections detail the correct field formats for the data in the flat files.

4.3.1 Alphanumeric Fields

Alphanumeric fields are identified in Appendix B as Data Type "A" fields. Data Type "A" fields must be left-justified with all trailing spaces filled with the space character (i.e., ASCII HEX 0x20 or ASCII Decimal 32).

Valid characters for alphanumeric fields are limited to:

~!#\$%^*()_+`-\=:;?.,/'"@&1234567890ABCDEFGHIJKLMNPOQRSTUVWXYZ

Invalid characters for alphanumeric fields include:

{ } [] < > | (concatenation character)

As part of the BRState Software load routines, all lowercase letters (a-z) will be converted to uppercase characters (A-Z). Lowercase letters will not cause a submission to be rejected, however the lowercase letters will be converted to uppercase characters.

4.3.2 Integer Fields

Integer fields are identified in Appendix B as Data Type "I" fields. Data Type "I" fields must be right-justified.

Allowed values for Integer Fields are number 0-9, and the space character (ASCII Hex 0x20 or ASCII Decimal 32).

Examples of incorrect and correct entries for an integer field defined with a length of five (5) are presented in Exhibit 2 below.

INCORRECT	CORRECT
1A	1
10,000	10000
750.25	750

Exhibit 2. Incorrect and Correct Integer Entries

4.3.3 Fixed Decimal Fields

Fixed place decimal fields are identified in Appendix B as Data Type "D" fields.

For all "D" field entries, the flat file specifications indicate the number of digits before the decimal and the number of digits after decimal that the data element is allowed. For example, D11.6 indicates that the number may have up to 11 digits before the decimal and 6 digits after the decimal (9999999999.999999). The period (.) character, representing the decimal must be included for fixed decimal fields. The field length includes the decimal character.

Allowed values for Fixed Decimal Fields are number 0-9, the decimal character ".", and the space character (ASCII Hex 0x20 or ASCII Decimal 32).

Although some data blocks on the *2011 Hazardous Waste Report, Instructions and Forms* provide for only one decimal place, the translator flat files may require that additional decimal places be represented in "D" fields. Exhibit 3 shows incorrect and correct entries in a type "D5.2" field.

INCORRECT	CORRECT
10,032.1	10032.10
98765	98765.00

Exhibit 3. Incorrect and Correct Fixed Decimal Entries

4.3.4 Sequence Number Fields

Some of the files in Appendix B require a sequence number to be provided for each record. The SI3 file, for example, requires a sequence number (NAICS_SEQ) for the NAICS codes. The sequence number is needed for data elements, such as the NAICS code, which may have more than one value. The sequence number takes the value "0001" for the first occurrence of the sequenced data element for the EPA ID and is then incremented by one with each successive occurrence of that same EPA ID.

4.3.5 Negative Numbers

Negative numbers are not allowed in the data submission.

4.4 Indicating Don't Know (DK) and Not Applicable (NA)

The *2011 Hazardous Waste Report, Instructions and Forms* do not allow the use of "Don't Know" (DK) or "Not Applicable" (NA). Flat files cannot contain any values indicating "Don't Know" or "Not Applicable."

4.5 Record Termination

Each flat file record must be terminated by a line feed character (ASCII Hex 0x0A or ASCII Decimal 010), or a carriage return character (ASCII Hex 0x0D or ASCII Decimal 013) followed by a line feed character.

4.6 Empty Fields

For fields that require no response, the field should be filled with the space character (i.e., blanks).

4.7 Flat File Hierarchy

Appendix G shows the flat file hierarchy for the Hazardous Waste Report data submission. Files connected by lines have a parent - child relationship. The file identified at the left terminus of a line is the parent. The file identified at the right terminus of a line is the child. Each record with a unique EPA ID in a child flat file must have at least one corresponding record in the parent flat file. When a parent flat file distinguishes records using more than one key, it is the combination of the keys that identifies uniqueness. For example, the "GM" series flat files use two keys (Handler ID and GM Page Number) to identify each "waste" being reported for a site. Thus, for each unique occurrence of the combined keys (Handler ID and Page Number) in the GM2 flat file, there must be a corresponding record in the GM1 file with the same values for the entire key.

4.8 Confidential Business Information (CBI)

Under existing RCRA statutes, sites may claim that certain items of information submitted as part of their Hazardous Waste Report contain Confidential Business Information (CBI). The procedures for handling CBI can be found in the *Procedures for Handling RCRA Confidential Business Information* (available from the EPA HQ RCRA Document Control Officer). A subset of these procedures is documented in the *Procedures for handling RCRA Confidential Business Information submitted for the Biennial Report*. (Copies of these documents can be requested from the Implementing State). In brief, it is not allowable to mingle CBI data with non-CBI data. In addition, CBI data must be handled on a secure computer (either a computer that is kept in a secure environment or a computer which uses removable media where the media is kept in a secure environment).

If any information for a site is claimed to be CBI for the purposes of the Hazardous Waste Report, **all** data for that site must be handled as CBI. CBI data must be submitted separately from non-CBI data.

APPENDIX A

National and System Required Data Elements

APPENDIX A - National and System Required Data Elements

A.1 National Data Elements

FLAT FILE ID	FIELD NAME	DESCRIPTION	FORM LOCATION
(all)	HANDLER_ID	EPA Identification Number	SI-2, GM, WR
GM1, WR1	UNIT_OF_MEASURE	Unit of Measure	GM-1-H, WR-F
GM1, WR1	WST_DENSITY	Density	GM-1-H, WR-F
GM1, WR1	DENSITY_UNIT_OF_MEASURE	Density Unit of Measure	GM-1-H, WR-F
GM1	GEN_QTY	Quantity Generated in Reporting Year	GM-1-G
GM1	SOURCE_CODE	Source Code	GM-1-D
GM1	ORIGIN_MANAGEMENT_METHOD	Origin Management Method	GM-1-D
GM5, WR1	MANAGEMENT_METHOD	Management Method	GM-2, WR-I
GM1	FORM_CODE	Physical waste description code	GM-1-F, WR-H
GM2, WR2	EPA_WASTE_CODE	EPA Hazardous Waste Code	GM-1-B, WR-B
GM4, WR1	IO_TDR_ID	EPA ID Number of Off-site Facility	GM-3-B, WR-D
GM4, WR1	IO_TDR_QTY	Total Quantity Shipped (GM4) or Total Quantity Received (WR1) in Current Reporting Year	GM-3-D, WR-E
GM5	SYS_TDR_QTY	Quantity Treated, Disposed or Recycled On-site in Current Reporting Year	GM-2

A.2 System Required Elements

FLAT FILE ID	FIELD NAME	DESCRIPTION
GM (all), WR (all)	HZ_PG	Form Page Number
GM4	IO_PG_NUM_SEQ	Off-site Sequence Number
GM5	SYS_PG_NUM_SEQ	On-site Sequence Number
WR (all)	SUB_PG_NUM	Waste Number

APPENDIX B

Flat File Specifications

APPENDIX B - Flat File Specifications

B.1 Key For Flat File Tables

Data Class

N	National
S	Shared
R	System Required
K	Key Field

Data Type

A	Alphanumeric
I	Integer
D	Fixed Decimal

B.2 Flat File Naming Convention

Flat files names are constructed in the following manner:

The flat file names must conform to the following naming conventions. Each flat file name is a combination of the reporter's EPA identification number and the alphanumeric flat file identifier. Each filename begins with the letter "H" followed by the characters 4 through 10 of the reporter's EPA ID, followed by a period (.), followed by the two-character flat file identifier, and ends with the eleventh character in the respondent's EPA ID.

For example, for a facility with the EPA ID of **ABD123456789**

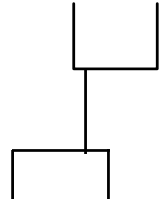

The GM1 flat file would be named:	H1234567.G18
The GM2 flat file would be named:	H1234567.G28
The WR1 flat file would be named:	H1234567.R18
The OI1 flat file would be named:	H1234567.O18
...etc.	

All flat files for one site should be stored in a similarly named directory/folder beginning with "O" instead of "H" and including the 11th and 3rd digit of the ID and last digit of the report year in the extension. This will make import into BRState much easier.

For the above example the folder would be named:

Like **O1234567.8D(1,3,5,7,9 for 2001,2003,etc.)**
O1234567.8D1 for 2011

B.3 Flat Files

The form SI is best submitted on paper or paper printouts with the flat files generated by BRState included in the submission flat file set. In either case, a paper form SI must be submitted with an original certifying signature and date. The naming convention for the electronic submission flat files follows the pattern above where the first two characters in the file name extension would be S1-S9.

For the example above, the SI3 file would be named: H1234567.S31

The flat file specifications for the SI files are included in the RCRAInfo File Specification Guide for the 2011 Hazardous Waste Report Submissions available from EPA. If you need this guide it may be found at:

<http://www.epa.gov/epawaste/inforesources/data/biennialreport/index.htm>

After generating the flat file sets from the specifications below, you should enter form SI data using the BRState software and then import the GM, WR and OI(if required) into the program using the import features. Use the "submit your data" function of the software to create a diskette containing the electronic data flat files only after checking the data for errors and inconsistencies. At the same time, you should print out and sign Form SI for inclusion in the submission package. You may also want to print the other forms for your records at this time. It is not necessary to send these other printouts with your submission.

The data assessments following the flat file specifications must be observed for a valid submission. These edits will be performed by the BRState software data checking functionality. Corrections to the data may be performed using the BRState software , or by re-generating the flat files after the source data or translation program has been corrected.

Each site will have its own file set generated in its own directory. You may include multiple submissions on one diskette, but you should ensure that the files are segregated into their respective directories(folders) by EPA ID. If you choose to PKZip your data it should also be segregated by ID into ZIP files named following this convention: EPAID|BR|Year. For the above example, the file would be named: ABD123456789BR2011.ZIP

FLAT FILE ID# - GM1

Source Form: GM **Description:** Waste Measurement Information

This file captures data elements that have a 1:1 relationship to the reported waste. These data elements are as follows: GM Section 1, Block A and Blocks D through G.

Key Fields: Handler ID Number (HANDLER_ID); Page Number (HZ_PG). Each record in the GM1 file must contain a unique combination of the Handler ID Number and Page Number.

Note: The GM1 File is REQUIRED for handlers that generated RCRA hazardous waste that, in 2011, was accumulated on-site; managed on-site in a treatment, storage, or disposal unit; and / or shipped off-site for management.

Field No.	Field Name	Starting Column	Field Length	Data Type	Description	Location on Form	Edit Number
1	HANDLER_ID	1	12	A	Reporting Site 's EPA ID Number	ID Block	GM000
2	HZ_PG	13	5	I	Page Number - Assigned By Respondent	Bottom	GM010
3	FORM_CODE	18	4	A	Waste Form Code	GM-1-E	GM220
4	UNIT_OF_MEASURE	22	1	A	(Pounds = '1', Short Tons = '2', Kilograms = '3', Metric Tonnes = '4', Gallons = '5', Liters = '6', Cubic Yards = '7')	GM-1-F	GM020
5	WST_DENSITY	23	6	D3.2	Density	GM-1-F	GM030,40
6	DENSITY_UNIT_OF_MEASURE	29	1	A	Density Unit of Measure (lbs/gal = '1', sg = '2')	GM-1-F	GM030
7	ORIGIN_MANAGEMENT_METHOD	30	4	A	Origin management method for source code G25 only	GM-1-D	GM230
8	WASTE_MIN_CODE	34	1	A	Federal Waste minimization Code (Y,N,S,R,X)	GM-1-G	GM360
9	SOURCE_CODE	35	3	A	Source Code	GM-1-D	GM270
10	GEN_QTY	38	18	D11.6	Quantity Generated in Reporting Year	GM-1-F	GM050
11	INCLUDE_IN_NATIONAL_REPORT	56	1	A	Include in the National Waste Report (Yes = 'Y', No = 'N')		GM310
12	DESCRIPTION	57	240	A	Waste Stream Description	GM-1-A	
13	NOTES	297	240	A	Comments/Notes	Bottom	
14	ON_SITE_MANAGEMENT	537	1	A	Was this Waste Managed On-Site (Yes = 'Y', No = 'N')	GM-2	GM320, 30, GM335
15	OFF_SITE_SHIPMENT	538	1	A	Was this Waste Shipped Off-Site(Yes = 'Y', No = 'N')	GM-3-A	GM340, 50, GM355
Total Record Length:			538				

FLAT FILE ID# - GM3

Source Form: GM **Description:** State Hazardous Waste Codes for each GM page

This file captures the information contained in Section 1, Block C of the GM form. The relationship of these data records to the reported waste is *n:1*, that is, there can be multiple State waste codes for each unique reported waste.

Key Fields: Handler ID Number (HANDLER_ID); Page Number (HZ_PG); State Hazardous Waste Code (WASTE_CODE). Each record in the GM3 file must contain a unique combination of the Handler ID Number, Page Number, and State Hazardous Waste Code.

Note: For each waste stream, either EPA Hazardous Waste Code information (GM2) is REQUIRED or State Hazardous Waste Code information (GM3) is REQUIRED.

Field No.	Field Name	Starting Column	Field Length	Data Type	Description	Location on Form	Edit Number
1	HANDLER_ID	1	12	A	EPA ID Number	Site ID Block	GM280
2	HZ_PG	13	5	I	Page Number	Assigned by respondent	
3	WASTE_CODE	18	6	A	State Hazardous Waste Code	GM-1-C	GM300
Total Record Length:			23				

FLAT FILE ID# - GM4

Source Form: GM **Description:** Off-Site Management Information for the Reported Waste on Each GM
Page

This file captures off-site treatment information for the reported waste as represented in GM Section 3, Blocks B through D. The relationship of these data records to the reported waste is *n:1*, that is, there can be multiple off-site information for each unique reported waste.

Key Fields: Handler ID Number (HANDLER_ID); Page Number (HZ_PG); Off-site Sequence Number (IO_PG_NUM_SEQ). Each record in the GM4 file must contain a unique combination of the Handler ID Number, Page Number, and Off-site Sequence Number.

Note: The GM4 File is REQUIRED for handlers that generated RCRA hazardous waste that, in 2011, was shipped off-site for management.

Field No.	Field Name	Starting Column	Field Length	Data Type	Description	Location on Form	Edit Number
1	HANDLER_ID	1	12	A	EPA ID Number	Site ID Block	GM110
2	HZ_PG	13	5	I	Page Number	Assigned by Respondent	
3	IO_PG_NUM_SEQ	18	5	I	Off-site Sequence Number	GM-3 Site# Block	GM120
4	MANAGEMENT_METHOD	23	4	A	Off-site Management Method	GM-3-C	GM160
5	IO_TDR_ID	27	12	A	EPA ID No. of Off-site Facility Shipped to	GM-3-B	GM140
6	IO_TDR_QTY	39	18	D11.6	Total Quantity Shipped to EPA ID in Field 5 in Current Reporting Year	GM-3-D	GM150
Total Record Length:			56				

FLAT FILE ID# - GM5

Source Form: GM **Description:** On-site Management Information for the Reported Waste on Each GM Page.

This file captures on-site treatment information as contained in Section 2 of the GM form. The relationship of the data element to the reported waste is *n:1*, that is, there can be multiple on-site information for each unique reported waste.

Key Fields: Handler ID Number (HANDLER_ID); Page Number (HZ_PG); On-site Sequence Number (SYS_PG_NUM_SEQ). Each record in the GM5 file must contain a unique combination of the Handler ID Number, Page Number, and On-site Sequence Number.

Note: The GM5 File is REQUIRED for handlers that generated RCRA hazardous waste that, in 2011, was accumulated on-site or managed on-site in a treatment, storage, or disposal unit.

Field No.	Field Name	Starting Column	Field Length	Data Type	Description	Location on Form	Edit Number
1	HANDLER_ID	1	12	A	EPA ID Number	Site ID Block	GM170
2	HZ_PG	13	5	I	Page Number	Assigned by Respondent	
3	SYS_PG_NUM_SEQ	18	5	I	On-site Sequence Number	GM-2 System# Block	GM180
4	MANAGEMENT_METHOD	23	4	A	On-site Management Method	GM-2	GM210
5	SYS_TDR_QTY	27	18	D11.6	Quantity Treated, Disposed, or Recycled On-site in Current Reporting Year	GM-2	GM190
Total Record Length:			44				

FLAT FILE ID# - WR1

Source Form: WR **Description:** Received Waste Description and Measurement Information

This file captures the information contained in Block A and Blocks D through H of the WR form. The relationship of these data records to the reported site is *n:1*, that is, there can be multiple received waste for each site.

Key Fields: Handler ID Number (HANDLER_ID); Page Number (HZ_PG); Waste Number (SUB_PG_NUM). Each record in the WR1 file must contain a unique combination of Handler ID Number, Page Number, and Waste Number.

Note: The WR1 is REQUIRED for handlers who, during 2011, received RCRA hazardous waste from off-site.

Field No.	Field Name	Starting Column	Field Length	Data Type	Description	Location on Form	Edit Number
1	HANDLER_ID	1	12	A	Site's EPA ID Number	ID Block	WR000
2	HZ_PG	13	5	I	Page Number	Assigned by Respondent	WR010
3	SUB_PG_NUM	18	1	I	Waste Number - Printed on the Form (1,2,3)	On Form	WR020
4	FORM_CODE	19	4	A	Form Code	WR-G	WR180
5	UNIT_OF_MEASURE	23	1	A	(Pounds = '1', Short Tons = '2', Kilograms = '3', Metric Tonnes = '4', Gallons = '5', Liters = '6', Cubic Yards = '7')	WR-F	WR030
6	WST_DENSITY	24	6	D3.2	Density	WR-F	WR040,50
7	DENSITY_UNIT_OF_MEASURE	30	1	A	Density Unit of Measure (lbs/gal = '1', sg = '2')	WR-F	WR040
8	INCLUDE_IN_NATIONAL_REPORT	31	1	A	Include n the National Report(Yes = 'Y', No = 'N')		WR230
9	MANAGEMENT_METHOD	32	4	A	Management Method	WR-H	WR060
10	IO_TDR_ID	36	12	A	Off-site Source EPA ID Number	WR-D	WR070
11	IO_TDR_QTY	48	18	D11.6	Quantity Received in Current Reporting Year	WR-E	WR080
12	DESCRIPTION	66	240	A	Waste Stream Description	WR-A	
13	NOTES	306	240	A	Comments/Notes	Bottom of WR Form	
Total Record Length:			546				

FLAT FILE ID# - WR2

Source Form: WR **Description:** EPA Hazardous Waste Codes for Each Reported Waste Received

This file contains the EPA hazardous waste codes for each WR form page as described in Form WR, Block B. The relationship of these data records to the reported waste is *n:1*, that is, there can be multiple EPA waste codes for each unique reported waste.

Key Fields: Handler ID Number (HANDLER_ID); Page Number (HZ_PG); Waste Number (SUB_PG_NUM); EPA Hazardous Waste Code (EPA_WASTE_CODE). Each record in the WR2 file must contain a unique combination of the Handler ID Number, Page Number, Waste Number, and EPA Hazardous Waste Code.

Note: For each waste stream, either EPA Hazardous Waste Code information (WR2) is REQUIRED or State Hazardous Waste Code information (WR3) is REQUIRED.

Field No.	Field Name	Starting Column	Field Length	Data Type	Description	Location on Form	Edit Number
1	HANDLER_ID	1	12	A	EPA ID Number	Site ID Block	WR090, WR130
2	HZ_PG	13	5	I	Page Number	Assigned by Respondent	
3	SUB_PG_NUM	18	1	I	Waste Number	Printed on Form	WR020
4	EPA_WASTE_CODE	19	4	A	EPA Hazardous Waste Code	WR-B	WR110
Total Record Length:			22				

FLAT FILE ID# - WR3

Source Form: WR **Description:** State Hazardous Waste Codes for Each Reported Waste Received

This file contains the State hazardous waste codes for each WR form page as described in Form WR, Block C. The relationship of these data records to the reported waste is n:1, that is, there can be multiple State waste codes for each unique reported waste.

Key Fields: Handler ID Number (HANDLER_ID); Page Number (HZ_PG); Waste Number (SUB_PG_NUM); State Hazardous Waste Code (WASTE_CODE). Each record in the WR3 file must contain a unique combination of the Handler ID Number, Page Number, Waste Number, and State Hazardous Waste Code.

Note: For each waste stream, either EPA Hazardous Waste Code information (GM2) is REQUIRED or State Hazardous Waste Code information (GM3) is REQUIRED.

Field No.	Field Name	Starting Column	Field Length	Data Type	Description	Location on Form	Edit Number
1	HANDLER_ID	1	12	A	EPA ID Number	Site ID Block	WR200
2	HZ_PG	13	5	I	Page Number	Assigned by Respondent	
3	SUB_PG_NUM	18	1	I	Waste Number	Printed on Form	WR020
4	WASTE_CODE	19	6	A	State Hazardous Waste Code	WR-C	WR220
Total Record Length:			24				

FLAT FILE ID# - OI1

Source Form: OI and Transporters **Description:** Identification of All Handlers to Whom or From Whom Waste was Shipped,

This file captures information from the OI form. *This flat file should never be included in submissions to RCRAInfo.*

Key Fields: Handler ID Number (HANDLER_ID); Page Number (OSITE_PGNUM). Each record in the OI1 file must contain a unique combination of EPA ID Number and Page Number.

Field No.	Field Name	Starting Column	Field Length	Data Type	Description	Location on Form	Edit Number
1	HANDLER_ID	1	12	A	EPA ID Number	Site ID Block	
2	OSITE_PGNUM	13	5	I	Page Number	Assigned by Respondent	
3	OFF_ID	18	12	A	Off-site Installation or Transporter EPA ID Number	OI-A	
4	WST_GEN_FLG	30	1	A	Handler Type = Generator (Checked = 'Y', Unchecked and not implementer required = 'U', Unchecked and implementer required = 'N')	OI-C	
5	WST_TRNS_FLG	31	1	A	Handler Type= Transporter (Checked = 'Y', Unchecked and not implementer required = 'U', Unchecked and implementer required = 'N')	OI-C	
6	WST_TSDR_FLG	32	1	A	Handler Type = TSDR (Checked = 'Y', Unchecked and not implementer required = 'U', Unchecked and implementer required = 'N')	OI-C	
7	ONAME	33	40	A	Name of Off-site Installation or Transporter	OI-B	
8	O1STREET	73	30	A	1st Street Address Line of Installation or Transporter	OI-D	
9	O2STREET	103	30	A	2nd Street Address Line of Installation or Transporter	OI-D	
10	OCITY	133	25	A	City	OI-D	
11	OSTATE	158	2	A	State	OI-D	
12	OZIP	160	9	A	Zip Code	OI-D	
13	NOTES	169	240	A	Comments/Notes	Bottom of OI Form	
Total Record Length:			408				

APPENDIX C

Data Assessment Edits

APPENDIX C - Data Assessment Edits

All data submitted must meet the appropriate data assessment edits. The data assessment edits for shared data elements applies only if the data is provided. For child table records, data assessment edits apply only if the record is being submitted.

C.1 Generic Data Edits

Edit Number	Form Location	Edit Description	Select Logic*
GN000	All	A non-valid character was found in a character field.	CHARACTER = allowed value as specified in Section 4.3.1
GN010	All	Alphabetic character found in numeric field.	NUMERIC_DIGIT = allowed value as specified in Section 4.3.2 or Section 4.3.3
GN020	All	Duplicate records found in file submission.	Combination of key fields for specific file must be unique

C.4 Form GM Edits

Edit Number	Form Location	Edit Description	Select Logic
GM000	GM	GM1 record is present, but corresponding record does not exist in the SI1 file.	HANDLER_ID in SI1file
GM010	GM	Page number must be greater than zero.	HZ_PG > 0
GM020	GM-1-H	Generated quantity unit of measure must equal '1', '2', '3', '4', '5', '6', or '7'.	UNIT_OF_MEASURE = '1' or '2' or '3' or '4' or '5' or '6' or '7'
GM030	GM-1-H	If the generated quantity unit of measure is '5', '6' or '7' then density must be greater than zero and density unit of measure must be 1 or 2.	If UNIT_OF_MEASURE = '5', '6', or '7' Then WST_DENSITY > 0 AND DENSITY_UNIT_OF_MEASURE = 1 or 2
GM040	GM-1-H	Waste density must be greater than or equal to 0.01 and less than or equal to 999.99, or equal to 0.	WST_DENSITY >= 0.01 and <= 999.99 or WST_DENSITY = 0
GM050	GM-1-G	Quantity generated in the reporting year must be greater than or equal to 0.000001 and less than or equal to 99,999,999,998.999999, or equal to zero.	GEN_QTY >= 0.000001 and <= 99999999998.999999 or GEN_QTY = 0
GM060	GM	GM2 record is present, but corresponding record does not exist in the GM1 file.	HANDLER_ID and HZ_PG in GM1 file

Edit Number	Form Location	Edit Description	Select Logic
GM090	GM-1-B	EPA hazardous waste code must be an EPA waste code value specified in the <i>2011 Hazardous Waste Report, Instructions and Forms</i> .	EPA_WASTE_CODE = value specified in the <i>2011 Hazardous Waste Report, Instructions and Forms</i>
GM100	GM-1-B	EPA or State hazardous waste data must be provided.	HANDLER_ID and HZ_PG in GM1 file and in GM2 or GM3 file
GM110	GM	GM4 record is present, but corresponding record does not exist in the GM1 file.	HANDLER_ID and HZ_PG in GM1 file
GM120	GM - Assigned by respondent	Off-site code sequence number must be greater than zero.	IO_PG_NUM_SEQ > 0
GM140	GM-3-B	The off-site shipment handler EPA ID number must begin with a valid state postal code.	SUBSTR(IO_TDR_ID,1,2) = valid state postal code (see Appendix F)
GM150	GM-3-D	Total quantity shipped off-site in the reporting year must be greater than or equal to 0.000001 and less than or equal to 99,999,999,998.999999.	IO_TDR_QTY >= 0.000001 and <= 99999999998.999999
GM160	GM-3-C	The off-site management method must be a management method specified in the <i>2011 Hazardous Waste Report, Instructions and Forms</i> or blank.	MANAGEMENT_METHOD = management method specified in the <i>2011 Hazardous Waste Report, Instructions and Forms</i> or blank.
GM170	GM	GM5 record is present, but corresponding record does not exist in the GM1 file.	HANDLER_ID and HZ_PG in GM1 file
GM180	GM - Assigned by respondent	On-site sequence number must be greater than zero.	SYS_PG_NUM_SEQ > 0
GM190	GM-2	Total quantity treated, disposed, or recycled on-site in the reporting year must be greater than or equal to 0.000001 and less than or equal to 99,999,999,998.999999.	SYS_TDR_QTY >= 0.000001 and <= 99999999998.999999
GM210	GM-2	The on-site management method must contain a management method specified in the <i>2011 Hazardous Waste Report, Instructions and Forms</i> .	MANAGEMENT_METHOD = value specified in the <i>2011 Hazardous Waste Report, Instructions and Forms</i>
GM220	GM-1-E	The form code must be a form code value specified in the <i>2011 Hazardous Waste Report, Instructions and Forms</i> or blank.	FORM_CODE = value specified in the <i>2011 Hazardous Waste Report, Instructions and Forms</i> or ''
GM230	GM-1-D	If source code equals G25 then the management method code must be a management method specified in the <i>2011 Hazardous Waste Report, Instructions and Forms</i> . If source code is not equal to G25 then the management method code must be blank.	If SOURCE_TYPE = 'G25' Then ORIGIN_MANAGEMENT_METHOD = value specified in the <i>2011 Hazardous Waste Report, Instructions and Forms</i> Else ORIGIN_MANAGEMENT_METHOD = ''

Edit Number	Form Location	Edit Description	Select Logic
GM270	GM-1-D	The source code must be a source code value specified in the <i>2011 Hazardous Waste Report, Instructions and Forms</i> .	SOURCE_CODE = value specified in the <i>2011 Hazardous Waste Report, Instructions and Forms</i>
GM280	GM	GM3 record is present, but corresponding record does not exist in the GM1 file.	HANDLER_ID and HZ_PG in GM1 file
GM300	GM-1-C	Waste code must be registered with the RCRAInfo database.	WASTE_CODE = implementer defined state waste code in LU_WASTE_CODE
GM310		If Include in National Report in the SI1 file equals 'N' then Include in National Report must be a 'N'. If Include in National Report in the SI1 file equals 'Y' then Include in National Report must be a 'Y' or 'N'.	If INCLUDE_IN_NATIONAL_REPORT = 'N' in the SI1 file Then INCLUDE_IN_NATIONAL_REPORT = 'N' Else INCLUDE_IN_NATIONAL_REPORT = 'Y' or 'N'
GM320	GM-2	On-site management indicator must equal 'Y' or 'N'	ON_SITE_MANAGEMENT = 'Y' or 'N'
GM330	GM-2	If On-site management indicator equals 'Y' then at least one corresponding record must exist in GM5 file.	If ON_SITE_MANAGEMENT = 'Y' Then HANDLER_ID and HZ_PG in GM5 file
GM335	GM-2	If On-site management indicator equals 'N' then no corresponding record may exist in GM5 file.	If ON_SITE_MANAGEMENT = 'N' Then no record in GM5 file for HANDLER_ID and HZ_PG
GM340	GM-3-A	Off-site management indicator must equal 'Y' or 'N'	OFF_SITE_SHIPMENT = 'Y' or 'N'
GM350	GM-3-A	If Off-site shipment indicator equals 'Y' then at least one corresponding record must exist in GM4 file.	If OFF_SITE_SHIPMENT = 'Y' Then HANDLER_ID and HZ_PG in GM4 file
GM355	GM-3-A	If Off-site shipment indicator equals 'N' then no corresponding record may exist in GM4 file.	If OFF_SITE_SHIPMENT = 'N' Then no record in GM4 for HANDLER_ID and HZ_PG
GM360	GM-1-G		

C.5 Form WR Edits

Edit Number	Form Location	Edit Description	Select Logic
WR010	WR	Page number must be greater than zero.	HZ_PG > 0
WR020	WR	Sub-page number must equal '1', '2', or '3'.	SUB_PG_NUM = '1' or '2' or '3'
WR030	WR-F	Unit of measure must equal '1', '2', '3', '4', '5', '6', or '7'.	UNIT_OF_MEASURE = '1' or '2' or '3' or '4' or '5' or '6' or '7'
WR040	WR-F	If the unit of measure is '5', '6' or '7' then density must be greater than zero and density unit of measure must be 1 or 2.	If UNIT_OF_MEASURE = '5', '6', or '7' Then WST_DENSITY > 0 AND DENSITY_UNITS = 1 or 2
WR050	WR-F	Waste density must be greater than or equal to 0.01 and less than or equal to 999.99, or equal to 0.	WST_DENSITY >= 0.01 and <= 999.99 or WST_DENSITY = 0
WR060	WR-H	Management method code must be a method specified in the <i>2011 Hazardous Waste Report, Instructions and Forms</i> .	MANAGEMENT_METHOD = value specified in the <i>2011 Hazardous Waste Report, Instructions and Forms</i>
WR070	WR-D	The first two characters of the off-site handler EPA ID number must be a valid postal code or 'FC' (foreign country).	SUBSTR(IO_TDR_ID,1,2) = valid postal code (see Appendix F) or 'FC'
WR080	WR-E	Total quantity received in the reporting year must be greater than or equal to 0.000001 and less than or equal to 99,999,999,998..	IO_TDR_QTY >= 0.000001 and <= 99999999998.999999
WR090	WR	WR2 record is present, but corresponding record does not exist in the WR1 file.	HANDLER_ID, HZ_PG, and SUB_PG_NUM in WR1 file
WR110	WR-B	EPA hazardous waste code must be an EPA waste code specified in the <i>2011 Hazardous Waste Report, Instructions and Forms</i> .	EPA_WASTE_CODE = value specified in the <i>2011 Hazardous Waste Report, Instructions and Forms</i>
WR130	WR-B	EPA or State hazardous waste data must be provided.	HANDLER_ID, HZ_PG, and SUB_PG_NUM in WR1 file and in WR2 or WR3 file
WR180	WR-G	The form code must be a form code specified in the <i>2011 Hazardous Waste Report, Instructions and Forms</i> or blank.	FORM_CODE = value specified in the <i>2011 Hazardous Waste Report, Instructions and Forms</i> or ''
WR200	WR	WR3 record is present, but corresponding record does not exist in the WR1 file.	HANDLER_ID, HZ_PG, and SUB_PG_NUM in WR1 file
WR220	WR-B	Waste code must be registered with the RCRAInfo database.	WASTE_CODE = implementer defined value
WR230		If Include in National Report in the SI1 file equals 'N' then Include in National Report must be 'N'. If Include in National Report in the SI1 file equals 'Y' then Include in National Report must be 'Y' or 'N'.	If INCLUDE_IN_NATIONAL_REPORT = 'N' in the SI1 file Then INCLUDE_IN_NATIONAL_REPORT = 'N' Else INCLUDE_IN_NATIONAL_REPORT = 'Y' or 'N'

APPENDIX D

Hazardous Waste Report Annotated Forms

<p>SEND THE COMPLETED FORM TO: The Appropriate State or EPA Regional Office.</p>	<p>United States Environmental Protection Agency</p> <p>RCRA SUBTITLE C SITE IDENTIFICATION FORM</p>		
<p>1. Reason for Submittal (See instructions on page 23)</p> <p>MARK ALL BOX(ES) THAT APPLY</p>	<p>Reason for Submittal: SI1-2</p> <p><input type="checkbox"/> To provide Initial Notification of Regulated Waste Activity (to obtain an EPA ID Number for hazardous waste, universal waste, or used oil activities).</p> <p><input type="checkbox"/> To provide Subsequent Notification of Regulated Waste Activity (to update site identification information).</p> <p><input type="checkbox"/> As a component of a First RCRA Hazardous Waste Part A Permit Application.</p> <p><input type="checkbox"/> As a component of a Revised RCRA Hazardous Waste Part A Permit Application (Amendment # _____).</p> <p><input checked="" type="checkbox"/> As a component of the Hazardous Waste Report.</p>		
<p>2. Site EPA ID Number (See page xx)</p>	<p>EPA ID Number: SI1-1</p> <p>_____</p>		
<p>3. Site Name (See page xx)</p>	<p>Name: SI1-3</p>		
<p>4. Site Location Information (See page xx)</p>	<p>Street Address: SI-4, SI-5, SI1-6</p>		
	<p>City, Town, or Village: SI1-7</p>	<p>State: SI1-9</p>	
	<p>County Name: SI1-8</p>	<p>Zip Code: SI1-10</p>	
<p>5. Site Land Type (See page xx)</p>	<p>Site Land Type: <input type="checkbox"/> Private <input type="checkbox"/> County <input type="checkbox"/> District <input type="checkbox"/> Federal <input type="checkbox"/> Indian <input type="checkbox"/> Municipal <input type="checkbox"/> State <input type="checkbox"/> Other</p> <p>SI1-18</p>		
<p>6. North American Industry Classification System (NAICS) Code(s) for the Site (See page xx)</p>	<p>A. SI6-3</p>	<p>B.</p>	
	<p>C.</p>	<p>D.</p>	
<p>7. Site Mailing Address (See page xx)</p>	<p>Street or P. O. Box: SI1-11, SI1-12, SI1-13</p>		
	<p>City, Town, or Village: SI1-14</p>		
	<p>State: SI1-15</p>		
	<p>Country: SI1-16</p>	<p>Zip Code: SI1-17</p>	
<p>8. Site Contact Person (See page xx)</p>	<p>First Name: SI1-19</p>	<p>MI: SI1-20</p>	<p>Last Name: SI1-21</p>
	<p>Phone Number: SI1-22 Extension: SI1-23</p>	<p>Email address: SI1-36</p>	

9. Operator and Legal Owner of the Site (See pages xx to xx)	A. Name of Site's Operator: SI9-4		Date Became Operator (mm/dd/yyyy): SI9-5	
	Operator Type: <input type="checkbox"/> Private <input type="checkbox"/> County <input type="checkbox"/> District <input type="checkbox"/> Federal <input type="checkbox"/> Indian <input type="checkbox"/> Municipal <input type="checkbox"/> State <input type="checkbox"/> Other SI9-6			
	B. Name of Site's Legal Owner: SI9-4		Date Became Owner (mm/dd/yyyy): SI9-5	
	Owner Type: <input type="checkbox"/> Private <input type="checkbox"/> County <input type="checkbox"/> District <input type="checkbox"/> Federal <input type="checkbox"/> Indian <input type="checkbox"/> Municipal <input type="checkbox"/> State <input type="checkbox"/> Other SI9-6			
	Street or P. O. Box: SI9-7, SI9-8, SI9-9			
	City: SI9-10			
	State: SI9-11			
	Country: SI9-13		Zip Code: SI9-12	

10. Type of Regulated Waste Activity

Mark Yes or No for all activities; complete any additional boxes as instructed. (See instructions on pages xx to xx.)

A. Hazardous Waste Activities

Complete all parts for 1 through 6.

Y N 1. Generator of Hazardous Waste

If Yes, choose only one of the following - a, b, or c.

SI1-25

- a. LQG: Greater than 1,000 kg/mo (2,200 lbs./mo.) of non-acute hazardous waste; or
- b. SQG: 100 to 1,000 kg/mo (220 - 2,200 lbs./mo.) of non-acute hazardous waste; or
- c. CESQG: Less than 100 kg/mo (220 lbs./mo.) of non-acute hazardous waste

In addition, indicate other generator activities.

Y N d. United States Importer of Hazardous Waste

SI1-26

Y N e. Mixed Waste (hazardous and radioactive) Generator

SI1-27

Y N 2. Transporter of Hazardous Waste

SI1-28

Y N 3. Treater, Storer, or Disposer of Hazardous Waste (at your site) Note: A hazardous waste permit is required for this activity.

SI1-29

Y N 4. Recycler of Hazardous Waste (at your site)

SI1-30

Y N 5. Exempt Boiler and/or Industrial Furnace If Yes, mark each that applies.

a. Small Quantity On-site Burner Exemption **SI1-31**

b. Smelting, Melting, and Refining Furnace Exemption **SI1-32**

Y N 6. Underground Injection Control

SI1-33

<p>B. Universal Waste Activities</p> <p>Y <input type="checkbox"/> N <input type="checkbox"/> 1. Large Quantity Handler of Universal Waste (accumulate 5,000 kg or more) [refer to your State regulations to determine what is regulated]. Indicate types of universal mark all boxes that apply:</p> <p style="text-align: right; margin-right: 100px;"><u>Generate / Accumulate</u></p> <p>a. Batteries <input type="checkbox"/> SI2-3</p> <p>b. Pesticides <input type="checkbox"/> SI2-5</p> <p>c. Thermostats <input type="checkbox"/> SI2-7</p> <p>d. Lamps <input type="checkbox"/> SI2-9</p> <p>e. Other (specify) <u>SI3-2</u> <input type="checkbox"/> SI3-4</p> <p>f. Other (specify) _____ <input type="checkbox"/></p> <p>g. Other (specify) _____ <input type="checkbox"/></p> <p>Y <input type="checkbox"/> N <input type="checkbox"/> 2. Destination Facility for Universal Waste Note: A hazardous waste permit may be required for this activity. SI2-10</p>	<p>C. Used Oil Activities Mark all boxes that apply.</p> <p>Y <input type="checkbox"/> N <input type="checkbox"/> 1. Used Oil Transporter If Yes, mark each that applies.</p> <p><input type="checkbox"/> a. Transporter SI2-11</p> <p><input type="checkbox"/> b. Transfer Facility SI2-12</p> <p>Y <input type="checkbox"/> N <input type="checkbox"/> 2. Used Oil Processor and/or Re-refiner If Yes, mark each that applies.</p> <p><input type="checkbox"/> a. Processor SI2-13</p> <p><input type="checkbox"/> b. Re-refiner SI2-14</p> <p>Y <input type="checkbox"/> N <input type="checkbox"/> 3. Off-Specification Used Oil Burner SI2-15</p> <p>Y <input type="checkbox"/> N <input type="checkbox"/> 4. Used Oil Fuel Marketer If Yes, mark each that applies.</p> <p><input type="checkbox"/> a. Marketer Who Directs Shipment of Off-Specification Used Oil to Off-Specification Used Oil Burner SI2-16</p> <p><input type="checkbox"/> b. Marketer Who First Claims the Used Oil Meets the Specifications SI2-17</p>
---	---

11. Description of Hazardous Wastes (See instructions on page xx)

A. Waste Codes for Federally Regulated Hazardous Wastes. Please list the waste codes of the Federal hazardous wastes handled at your site. List them in the order they are presented in the regulations (e.g., D001, D003, F007, U112). Use an additional page if more spaces are needed.

SI4-2						

B. Waste Codes for State-Regulated (i.e., non-Federal) Hazardous Wastes. Please list the waste codes of the State-regulated hazardous wastes handled at your site. List them in the order they are presented in the regulations. Use an additional page if more spaces are needed for waste codes.

SI5-2						

12. Comments (See instructions on page xx)

SI1-35

13. Certification. I certify under penalty of law that this document and all attachments were prepared under my direction or supervision in accordance with a system designed to assure that qualified personnel properly gather and evaluate the information submitted. Based on my inquiry of the person or persons who manage the system, or those persons directly responsible for gathering the information, the information submitted is, to the best of my knowledge and belief, true, accurate, and complete. I am aware that there are significant penalties for submitting false information, including the possibility of fine and imprisonment for knowing violations.

(See instructions on page xx)

Signature of owner, operator, or an authorized representative	Name and Official Title (type or print)	Date Signed (mm/dd/yyyy)
	SI7-3, SI7-4, Si7-5, SI7-6	SI7-7

APPENDIX E

EPA Check Digit Routine

APPENDIX E - EPA ID Check Digit Routine

E.1 Characteristics of an EPA ID

All EPA ID's must meet the following requirements:

- ⊃ Only characters A-Z, 0-9 and blank are allowed
- ⊃ The first two characters must be a valid state code (see Appendix H)
- ⊃ The EPA ID must be at least three (3) characters in length (not including blanks).

At this time EPA is not requiring that EPA IDs pass check digit routines. However, reporters may choose to check their EPA IDs against the check digit routines. The below routines are the guidelines that EPA has used for EPA IDs in previous BR cycles:

- ⊃ If the third character of the EPA ID is 'D' or 'R', the EPA ID must pass the Modulus 10 check digit routine below.
- ⊃ If the third character of the EPA ID is 0-9, the EPA ID must pass the Modulus 10 check digit routine or the alternate check digit routine below.

E.2 Parts of an EPA ID

POSITIONS IN THE ID	DATA	ALLOWED VALUES
1-2	State Postal Code	Alphabetic characters only, must be valid state postal code (see Appendix H)
3	Site designation	A-Z, 0-9
4-11	ID digits	A-Z, 0-9, or blank
12	Check digit	A-Z, 0-9, or blank

E.3 Modulus 10 Check Digit Routine

The Modulus 10 check digit is calculated according to the following algorithm:

1. BRState Software identifies the number in the 4th through 11th positions of the ID.
Example ID: MDD001947308 4th - 11th positions: 00194730
2. The combination of digits used to create the check digit is 12121212.
3. In order to determine / verify the 12th check digit:
 - a. Multiply each digit in the check combination by its positional mate.

0	0	1	9	4	7	3	0	
X 1	X 2	X 1	X 2	X 1	X 2	X 1	X 2	
0 +	0 +	1 +	1 + 8 +	4 +	1 + 4 +	3 +	0	22

- b. Sum the products, treating each one as a separate number (i.e. 18 becomes 1 and 8). In the example, the total is 22.

- c. Subtract this total (22) from the next highest multiple of 10 (i.e. 30 in this case).

$$30 - 22 = 8$$

Check digit = 8

(Note: If the result is 10, the check digit is zero).

E.4 Alternate Check Digit Routine

The check digit for IDs containing a digit (0-9) in the third character of the EPA ID must pass EITHER the Modulus 10 check digit routine or the following alternate check digit routine:

1. The value of the number in the 12th position of the ID is added to the previously calculated sum (from Step 3 above).
2. The resulting sum is subtracted from the next higher multiple of 10.
3. The result of the subtraction is compared to the value in the 3rd position in the EPA ID. If the values match, the EPA ID passes the alternate check digit routine.

E.5 Example Check Digit Calculations

The following table presents several examples of check digit calculations for illustration.

EPA ID	PASS/FAIL	COMMENTS
MDD123456782	Pass	Check sum is 38. Subtract 38 from next higher multiple of 10 (40) and compare to 12 th position of ID. $40 - 38 = 2 = 12^{\text{th}}$ position, therefore EPA ID passes check digit.
MDD223456782	Fail	Check sum is 39. Subtract 39 from next higher multiple of 10 (40) and compare to 12 th position of ID. $40 - 39 = 1$ which is not equal to the 12 th position (2), therefore EPA ID fails check digit.
MD1123456782	Pass	Check sum is 38. Subtract 38 from next higher multiple of 10 (40) and compare to 12 th position of ID. $40 - 38 = 2 = 12^{\text{th}}$ position, therefore EPA ID passes check digit.

EPA ID	PASS/FAIL	COMMENTS
MD9123456783	Pass	<p>Check sum is 38. Subtract 38 from next higher multiple of 10 (40) and compare to 12th position of ID. $40-38 = 2$ which is not equal to the 12th position (3), therefore EPA ID fails first check digit routine. Since the value in the 3rd position is numeric, the alternate check digit routine applies.</p> <p>For the alternate check digit routine, the check sum is $38+3=41$. The check sum is subtracted from the next higher multiple of 10 (50) and compared to the value in the 3rd position. In this case, the calculation is $50-41=9$ which equals the 3rd position. Therefore, the EPA ID passes the check digit routine.</p>
MD8123456783	Fail	<p>Check sum is 38. Subtract 38 from next higher multiple of 10 (40) and compare to 12th position of ID. $40-38 = 2$ which is not equal to the 12th position (3), therefore EPA ID fails first check digit routine. Since the value in the 3rd position is numeric, the alternate check digit routine applies.</p> <p>For the alternate check digit routine, the check sum is $38+3=41$. The check sum is subtracted from the next higher multiple of 10 (50) and compared to the value in the 3rd position. In this case, the calculation is $50-41=9$ which does not equal the 3rd position (8). Therefore, the EPA ID fails the check digit routine.</p>
MDCESQG	Pass	<p>The third character is not D, R or 0-9, therefore the ID does not need to pass a check digit routine.</p>

APPENDIX F

Example Flat Files

APPENDIX G

Flat File Hierarchy

FLAT FILE HIERARCHY

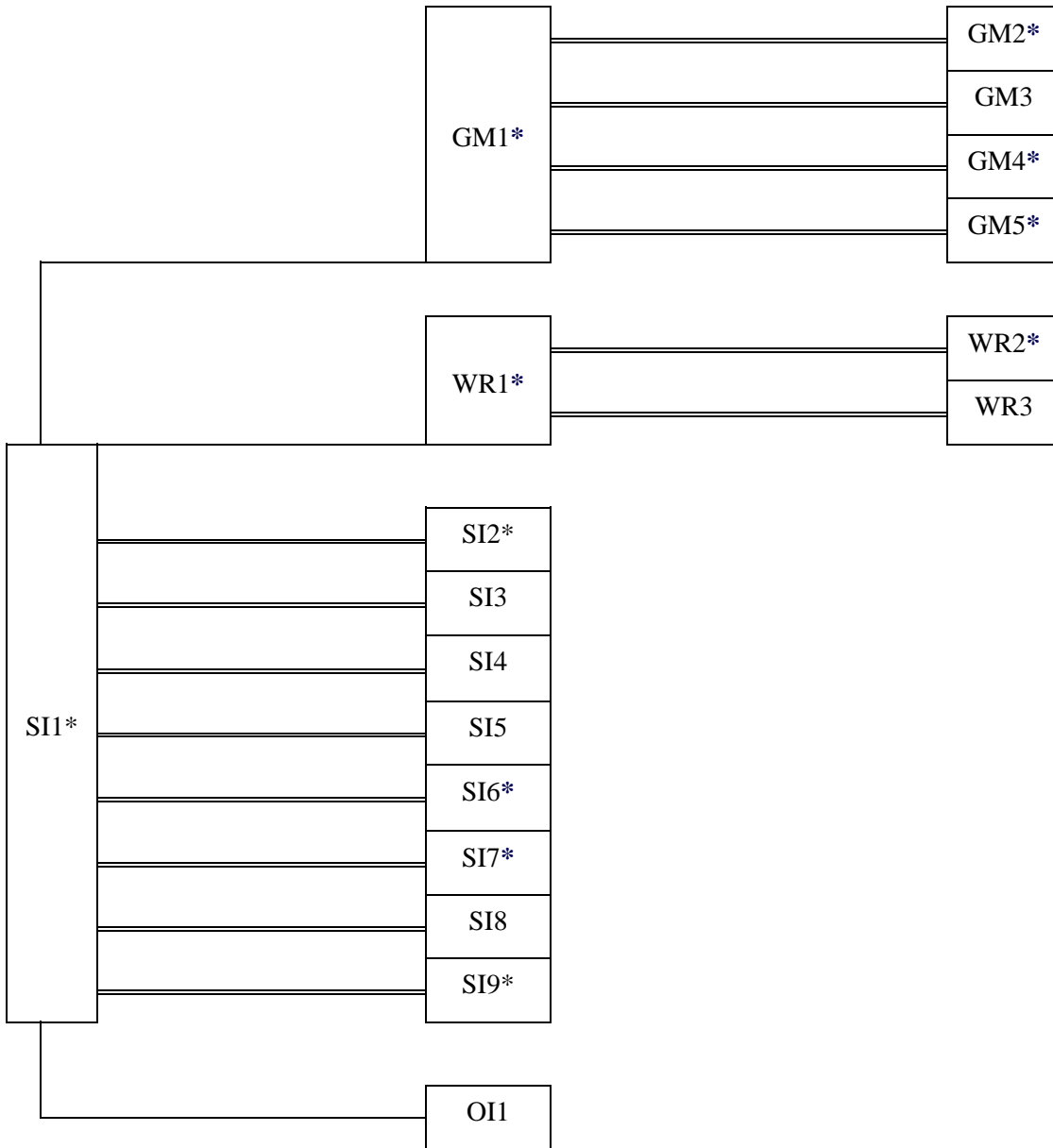

* These flat files contain required data elements.

NOTE: The OI1 flat file should never be included in the submission to RCRAInfo.

